Process Manual

For

open eir¹ Physical Co-Location Service

¹ open eir is a trading name of eircom limited, Registered as a Branch in Ireland Number 907674, Incorporated in Jersey Number 116389, Branch Address : 2022 Bianconi Avenue, Citywest Business Campus, Dublin 24 D24 HX03, Ireland

Version Control

| Version | Status | Update | Effective Date |
|---------|--------|-----------------|----------------|
| V17.0 | Final | D10/18 changes. | 31/05/2019 |

This document follows change control procedure:

Proposed is defined as a document status when the approved document is uploaded to Proposals Section of open eir Website.

Final is defined as a document status when the approved document is uploaded to the relevant section of the open eir Website following the publication period.

For information:

- Historical Document History Table located at end of Document.
- Publish means the action of uploading a document to the website regardless of status or location.
- **If there are changes to the document between 'Proposed' and 'Final', change control operates.**

Table of Contents

| | | |
|--------|---|----|
| 1. | Introduction | 7 |
| 1.1 | DEFINITIONS | 7 |
| 1.2 | SCOPE | 7 |
| 1.3 | DESCRIPTION OF PHYSICAL COLLOCATION SERVICE | 7 |
| 1.4 | DOCUMENT STATUS | 8 |
| 1.5 | CHANGE MANAGEMENT | 8 |
| 2. | Process Overview | 8 |
| 3. | Service Provisioning | 10 |
| 3.1 | INTRODUCTION | 10 |
| 3.2 | PROCESS OVERVIEW | 10 |
| 3.3 | PREREQUISITES | 11 |
| 3.4 | SHARING OF SPACE BY OPERATORS | 11 |
| 3.5 | PROVISION OF GENERIC INFORMATION | 11 |
| 3.5.1 | <i>Business Planning Information</i> | 11 |
| 3.5.2 | <i>Survey Information Library</i> | 12 |
| 3.6 | PROVISION OF SITE SPECIFIC INFORMATION | 12 |
| 3.6.1 | <i>Prerequisites</i> | 12 |
| 3.6.2 | <i>Site Specific Information Request</i> | 12 |
| 3.6.3 | <i>Site Specific Information Pack</i> | 13 |
| 3.7 | INITIAL SURVEY | 13 |
| 3.7.1 | <i>Definition</i> | 13 |
| 3.7.2 | <i>Prerequisites</i> | 13 |
| 3.7.3 | <i>Initial Survey Request</i> | 13 |
| 3.7.4 | <i>Initial Survey Request Acknowledgement</i> | 14 |
| 3.7.5 | <i>Initial Survey Report</i> | 14 |
| 3.8 | FULL SURVEY | 15 |
| 3.8.1 | <i>Definition</i> | 15 |
| 3.8.2 | <i>Prerequisites</i> | 15 |
| 3.8.3 | <i>Full Survey Request Acknowledgement</i> | 16 |
| 3.8.4 | <i>Full Survey Report</i> | 16 |
| 3.8.5 | <i>Progression of CFSSOR</i> | 17 |
| 3.9 | SITE OFFER | 17 |
| 3.9.1 | <i>Definition</i> | 17 |
| 3.9.2 | <i>Prerequisites</i> | 17 |
| 3.9.3 | <i>Site Offer Request</i> | 17 |
| 3.9.4 | <i>Site Offer Request Acknowledgement</i> | 17 |
| 3.9.5 | <i>Site Offer</i> | 18 |
| 3.9.6 | <i>Order</i> | 19 |
| 3.10 | SITE PREPARATION | 19 |
| 3.10.1 | <i>Kick Off Meeting</i> | 19 |
| 3.10.2 | <i>Formal Acceptance</i> | 20 |
| 3.11 | EQUIPMENT INSTALLATION | 20 |
| 3.11.1 | <i>Site Access for Equipment Installation</i> | 20 |
| 3.11.2 | <i>Installation Personnel</i> | 21 |
| 3.11.3 | <i>Permissible Equipment</i> | 21 |
| 3.11.4 | <i>Health and Safety Requirements</i> | 21 |
| 3.11.5 | <i>Final Site Meeting</i> | 21 |
| 3.12 | CoLo CEI BACKHAUL CONNECTION | 21 |
| 3.13 | CoLo RACK INTERCONNECT TIE CABLE / RESOURCE SHARING | 22 |
| 3.14 | WHOLESALE ETHERNET INTERCONNECT LINK (WEIL) AND WHOLESALE SYMMETRICAL ETHERNET ACCESS (WSEA) IN-BUILDING HANDOVER (IBH) | 22 |
| 3.14.1 | <i>Quote for Infrastructure (QIB)</i> | 23 |

| | | |
|--------|---|----|
| 3.14.2 | <i>Provide Infrastructure Build (PIB)</i> | 24 |
| 3.15 | GROUPING OF REQUESTS | 24 |
| 3.16 | FORECASTING OF DEMAND AND PROVISION OF RESOURCES | 24 |
| 3.17 | SERVICE LEVELS | 24 |
| 3.18 | CESSATION | 25 |
| 3.19 | SPECIAL INSPECTION | 26 |
| 3.20 | RIGHT OF APPEAL | 27 |
| 3.21 | EQUIPMENT FOOTPRINTS | 27 |
| 3.22 | EXPANSION OF CAPACITY REQUEST | 27 |
| 3.22.1 | <i>Definition</i> | 27 |
| 3.22.2 | <i>Prerequisites</i> | 27 |
| 3.22.3 | <i>Expansion of Capacity Request</i> | 27 |
| 4. | Equipment Notification | 29 |
| 4.1 | EQUIPMENT REQUIREMENTS | 29 |
| 4.2 | NOTIFICATION | 29 |
| 4.2.1 | <i>Information</i> | 29 |
| 4.2.2 | <i>Supporting Documentation</i> | 29 |
| 4.3 | COLLOCATION EQUIPMENT REGISTER | 30 |
| 4.4 | EQUIPMENT REGISTRATION | 30 |
| 4.5 | INSTALLATION OF EQUIPMENT | 30 |
| 4.5.1 | <i>Over Voltage Protection (OVP)</i> | 30 |
| 4.6 | OBJECTIONS | 30 |
| 4.7 | NON-COMPLIANT EQUIPMENT | 31 |
| 4.8 | NOTIFICATION OF OPEN EIR EQUIPMENT | 31 |
| 5. | Access | 31 |
| 5.1 | ACCREDITATION | 31 |
| 5.1.1 | <i>Notification</i> | 31 |
| 5.1.2 | <i>Open eir Briefing</i> | 32 |
| 5.1.3 | <i>Use of Contractors</i> | 32 |
| 5.1.4 | <i>Escorted Access Registration</i> | 32 |
| 5.1.5 | <i>Unescorted Access Accredited Rights - for employees / contractors of accredited Operator's</i> | 32 |
| 5.2 | PHYSICAL / UNFORESEEN PHYSICAL CHANGE | 33 |
| 5.2.1 | <i>Physical Change</i> | 33 |
| 5.2.2 | <i>Unforeseen Physical Change</i> | 34 |
| 5.3 | ACCESS REQUEST | 34 |
| 5.3.1 | <i>Planned Access Request</i> | 34 |
| 5.3.2 | <i>Unplanned Access Request</i> | 35 |
| 5.3.3 | <i>Unescorted Access Requests</i> | 36 |
| 5.3.4 | <i>Special Access Requirements</i> | 36 |
| 5.3.5 | <i>Changes to Access Requests</i> | 36 |
| 5.4 | ACCESS TIMES | 36 |
| 5.5 | ACCESS LEAD TIMES | 37 |
| 5.5.1 | <i>Planned Access</i> | 37 |
| 5.5.2 | <i>Unplanned Access</i> | 37 |
| 5.5.3 | <i>Unescorted Access</i> | 38 |
| 5.6 | ON-SITE PROCEDURES | 38 |
| 5.6.1 | <i>Identification</i> | 38 |
| 5.6.2 | <i>Responsibilities of the Operator</i> | 38 |
| 5.6.3 | <i>Escorts</i> | 38 |
| 5.6.4 | <i>Working Practises</i> | 38 |
| 5.6.5 | <i>Access Records</i> | 38 |
| 5.6.6 | <i>Access by Multiple Operators</i> | 39 |
| 6. | Fault Repair | 39 |

| | | |
|-------|--|----|
| 6.1 | SCOPE | 39 |
| 6.2 | FAULT REPORTING | 39 |
| 6.3 | STATUSING & TARGET REPAIR TIMES | 39 |
| 6.4 | ESCALATION PROCEDURES..... | 40 |
| 6.5 | CLEARANCE | 40 |
| 7. | Planned and Unplanned Maintenance | 41 |
| 7.1 | PLANNED WORKS BY OPEN EIR | 41 |
| 7.1.1 | <i>Introduction.....</i> | 41 |
| 7.1.2 | <i>Preferred hours for major works.....</i> | 41 |
| 7.1.3 | <i>Notification Process and Timescale.....</i> | 41 |
| 7.1.4 | <i>Escalation</i> | 42 |
| 7.2 | PLANNED WORKS BY THE OPERATOR | 42 |
| 7.2.1 | <i>Access to Site.....</i> | 42 |
| 7.2.2 | <i>Scope of Works.....</i> | 42 |
| 7.3 | UNPLANNED OR EMERGENCY WORKS BY OPEN EIR..... | 42 |
| 7.4 | UNPLANNED WORKS BY THE OPERATOR | 42 |
| 7.4.1 | <i>Access to Site.....</i> | 42 |
| 7.4.2 | <i>Scope of Works.....</i> | 42 |
| 7.5 | CO-ORDINATION OF HAZARDOUS OPERATIONS..... | 42 |
| 8. | Billing | 43 |
| 8.1 | INTRODUCTION..... | 43 |
| 8.2 | BILLABLE EVENTS | 43 |
| 8.3 | PAYMENT TERMS | 44 |
| 8.4 | DISPUTED PAYMENTS | 44 |
| 9. | Appendix A - Initial Survey Request Form | 45 |
| | Appendix B - Survey & Offer Request Form | 46 |
| | Appendix C - Valid Fault Clearance Codes | 49 |
| | Appendix D - Access Record Form | 50 |
| | Appendix E - Equipment Notification Form | 51 |
| | Appendix F - Site Specific Information Request Form..... | 52 |
| | Appendix G - Hazardous Operations..... | 53 |
| | Appendix H - Contact and Escalation Points..... | 54 |
| | Appendix I - Notification of Access Form | 55 |
| | Appendix J - Site Preparation Works Certificate | 57 |
| | Appendix K - Workflows (For illustrative purposes only)..... | 59 |
| | APPENDIX L - CO-LOCATION EQUIPMENT REGISTER..... | 64 |
| | APPENDIX M – ID APPLICATION FORMS | 66 |
| | Appendix N - Installed Equipment Safety Certificate..... | 69 |
| | APPENDIX O - REQUEST FOR PLANNED WORKS | 70 |
| | Appendix P - Expansion of Capacity Form | 71 |
| | Appendix Q - Notification of Access Form..... | 74 |
| | Appendix R – Access Rights | 75 |
| | Appendix S – Quotation Infrastructure Build | 79 |
| | Appendix T – CoLo CEI Backhaul Connection..... | 80 |
| | Appendix U – CoLo Rack Interconnect Tie Cable | 81 |
| | Version Control History..... | 82 |

List of Tables

TABLE 1: FILE NAME EXAMPLES..... 10
TABLE 2: SERVICE PROVISIONING ACTIVITY TARGET TIMELINES 25
TABLE 3: TIME LINES FOR NOTIFICATION FOR UNESCORTED ACCESS. 33
TABLE 4: ACCESS TIMES 37
TABLE 5: PLANNED ACCESS LEAD-TIMES 37
TABLE 6: MAXIMUM LEAD TIMES FOR GAINING UNPLANNED ACCESS..... 37
TABLE 7: MAXIMUM LEAD TIMES FOR GAINING UNESCORTED ACCESS 38
TABLE 8: STATUS REPORT INTERVALS & TARGET REPAIR TIMES..... 40
TABLE 9: ESCALATION TIMES 40
TABLE 10: BILLABLE EVENTS 43

Table of Figures

FIGURE 1: WHOLESAL ETERNET INTERCONNECT LINK (WEIL) IN-BUILDING HANDOVER..... 23
FIGURE 2: WHOLESAL SYMMETRICAL ETERNET ACCESS (WSEA) IN-BUILDING HANDOVER..... 23

1. Introduction

This document contains a set of operational processes that support the interactions between Openeir and other licensed operators for the delivery and operation of physical co-location services in eir exchange facilities in connection with Local Loop Unbundling (“LLU”), NGA Virtual Unbundled Access (“VUA”), Interconnection (IBH variant), and Civil Engineering Infrastructure (CEI – duct/pole access).

Physical Co-location was developed to support LLU services from an open eir exchange building. This was extended to also support taking the open eir NGA VUA (Virtual Unbundled Access) service from an ‘NGA exchange’, i.e. an open eir exchange which has an NGA Aggregation Node installed (see the relevant NGA/WBARO product documentation). This latter product variant is referred to as ‘CoLo for VUA’.

This product is now further extended to also support an Operator taking either open eir Interconnect products with an IBH variant (see the relevant leased line product documentation - referred to as ‘CoLo for IBH’), or an Operator taking the open eir Duct / Pole Access Civil Engineering Infrastructure products (see the relevant duct/pole access product documentation - referred to as ‘CoLo for CEI’).

The Operator should contact their Account Manager for details on the products.

The product documentation and ARO Service Schedule and Licence Agreement for Physical CoLocation (for LLU) will now also cover Physical CoLocation for VUA, Physical CoLocation for IBH and Physical CoLocation for CEI.. The price list for CoLo (all variants) will be included in the ARO CoLo price list.

An Operator may choose to have an AC or DC power supply provided by open eir to service their equipment.

In all cases where CoLo is being installed in a new site with AC power provided by open eir, or where an Operator chooses to replace the existing open eir DC power with open eir AC power, then open eir requires that a power meter be included. Such a power meter can be used by both parties to validate the requested power.

1.1 Definitions

In this document, words and expressions are as defined in Open eir’s Access Reference Offer (ARO) and also open eir’s Wholesale Bistream Access Reference Offer (“WBARO” – ie. NGA VUA), and also open eir’s Leased Line Reference Offer (“LLRO”).

1.2 Scope

These processes apply to all of the Physical Co-Location product variants described in the Product Description document.

The scope of this document is limited to operational processes.

1.3 Description of Physical Collocation Service

This section presents a brief description of the Physical Collocation Service to provide a basic introduction to the service for those who are unfamiliar with the concept. For the definitive and more detailed description please refer to Open eir’s Access Reference Offer.

The Physical Collocation Service is offered by eir to other telecom operators for use in connection with the provision of services over the eir copper local access network as mandated by the EU Local Loop

Unbundling regulations², or for VUA in accordance with the WBARO, or for IBH interconnection products in accordance with the LLRO, or for CEI (duct/pole) products in accordance with the ARO

Physical Collocation provides other licensed telecom operators with serviced accommodation in eir exchange facilities for the location of the access and back-haul equipment that is necessary to provide unbundled services.

See Introduction section above.

1.4 Document Status

This document has been produced by eir on behalf of the industry process group, chaired by ComReg, on Physical Co-location operational processes. It is based on discussions that took place during a series of meetings of the process group.

1.5 Change Management

This document is part of an inter-linked set of documents, namely:

- Product description documents (service schedules)
- Collocation Process Manual
- Unbundled Local Metallic Path and Line Sharing Process Manual
- Technical Manual
- Copper Loop Frequency Management Plan (CLFMP)

The development of this document may necessarily lead to changes in the other related documents. Therefore, where such changes are identified, they will be annotated in this document and actions placed on the other documents for consideration of the issues and changes.

The document set shall be reviewed as and when appropriate so that lessons learned from the practical implementation of the products and processes can be rapidly used to inform and shape the product descriptions and the working relationships between the parties.

See the relevant NGA/WBARO product documentation for information on the NGA VUA product, the relevant LLRO product documentation for information on the Interconnection IBH product, and the relevant ARO product documentation for information on CEI (duct/pole) product.

The product documentation and Licence Agreement for Physical CoLocation will cover all CoLo variants.

2. Process Overview

The Physical Collocation service will require five main operational processes:

- Service Provisioning
- Fault Repair
- Planned and Unplanned Maintenance
- Access
- Billing.

² The Regulation of the European Parliament and the Council on unbundled access to the local loop, effective from December 31st 2000.

In addition there is an ancillary process for notification of colocation equipment types to industry. Each of these is described briefly below and in detail in subsequent sections of this document.

Service Provisioning

This process describes the entirety of provisioning the Physical Collocation service beginning with initial inquiries and surveys of eir exchange facilities, through ordering of the service, preparation of the serviced accommodation and ending with the installation of the Operator's equipment in the serviced accommodation.

It will also include processes for delivery of 'CoLo Rack Interconnect Tie Cable' and of 'CoLo CEI Backhaul Connection'

Fault Repair

This process describes the procedures to be followed by Operators when reporting faults relating to the facilities provided by eir.

Planned and Unplanned Maintenance

This process describes the arrangements by which Open eir will notify Operators of either planned or unplanned maintenance activities at eir Exchange Facilities that will or are likely to affect the Operator's equipment.

If there are two or more Operators, a sub-process will be required for a party (probably eir) to co-ordinate the undertaking of hazardous activities by one Operator with all parties present.

Access

eir will provide Operators with escorted access to their equipment at Open eir Exchange facilities, where unescorted access is not appropriate. This process describes the arrangements for ordering and delivering this service.

Billing

This process describes the arrangements for billing Operators for the Physical Collocation service and for resolving billing enquires.

File Name Conventions

All forms passed between the parties shall adhere to a set of file name conventions. Forms attached to e-mails passed between Operators and Open eir as part of the processes specified herein shall be named:

COLLO_form name_operator name operator's reference sequence number

Where:

- ✔ COLLO : is the prefix for all files of this type
- ✔ Valid form names are:
 - SSIR – Site Specific Information Request
 - ISR – Initial Survey Request
 - FSR – Full Survey Request
 - CSOR – Collocation Site Offer Request
 - CFSCSOR – Combined Full Survey and Collocation Site Offer Request
- ✔ Operator name is the registered trading name of the Operator.
- ✔ Operator's reference : is the order number for the transaction provided by the initiating operator
- ✔ Sequence number: is the number of iterations that have taken place with the form, incremented each time the order passes between the parties.

The following are examples of valid file names:

| File Name | Order activity |
|--|---|
| COLLO_SSIR_operator name_operator reference number_01 | Submission of a Site Specific Information Request to the AP by the Operator |
| COLLO_SSIR_operator name_operator reference number_02 | Acceptance or rejection of a Site Specific Information Request by the AP back to the Operator |
| COLLO_ISR_operator name_operator reference number_01 | Submission of an Initial Survey Request to the AP by the Operator |
| COLLO_ISR_operator name_operator reference number_02 | Acceptance or rejection of an Initial Survey Request by the AP back to the Operator |

Table 1: File name examples.

3. Service Provisioning

3.1 Introduction

Open eir will appoint an account manager(s) to handle inquiries and orders from Operators and that information will be exchanged by letter/email using standard forms.

3.2 Process Overview

There are nine sub-processes:

- Provision of Generic Information - Open eir provides summary information about all of its exchanges to facilitate business planning activities
- Provision of Site Specific Information - Open eir provides plans of a particular exchange that is of interest to an Operator
- Initial Survey - to determine the potential of an exchange to support colocation
- Full Survey - Open eir undertakes a full survey of the exchange facility and produces a report describing the work required to prepare the serviced accommodation, including an indicative quotation and estimated timescales
- Site Offer - Open eir prepares a commercial offer to provide the serviced accommodation
- Site Preparation - preparation of the exchange facility to provide the serviced accommodation requested by the Operator
- Equipment Installation - installation of the Operator's equipment.
- "CoLo CEI Backhaul Connection" – open eir connect from an Operator's serviced exchange footprint to a suitable open eir Underground Utility Box [UUB]. (Note Operator must have achieved 'UUB box/chamber access accreditation' as part of open eir Duct Access product)
- "CoLo Rack Interconnect Tie Cable" – open eir connects an Operator' Serviced Exchange Footprint to a Service Exchange Footprint licenced to a different Operator

The sub-processes are described in more detail in the following sections.

3.3 Prerequisites

The Physical Collocation Service is available to any telecommunications operator that is in possession of either a General Authorisation to provide local loop services.

Prior to using the Service Provisioning process, the Operator must sign the Access Reference Offer (ARO) and a non-disclosure agreement (NDA).

An Access Agreement must be signed before an SSIR, ISR, FSR, Site Offer Request or CFSCSOR is submitted.

When placing a firm order for Physical Collocation (see Section 3.9.6), the Operator must sign:

- ✔ license agreement.
as specified in eir's ARO.

If Operators require CoLo for VUA or CoLo for Interconnect or CoLo for CEI they should sign the ARO/WBARO/LLRO and the same Physical CoLo Licence will suffice for both products.

3.4 Sharing of Space by Operators

Under the Information Notice COMREG 01/01, Operators are permitted to share colocation space and equipment.

The issues surrounding this are mainly contractual, but will have some impact on processes, which will be determined when such an eventuality arises.

3.5 Provision of Generic Information

After the signing of a non-disclosure agreement by the Operator, Open eir will make available, immediately and without delay and not later than the time shown in Table 2, generic information to assist Operators with their business planning activities. An Operator ID shall also be provided, which shall be used by the Operator to identify itself in all subsequent order transactions.

All LLU operators also have access to further information placed on the Open eir HUB. The information made available includes a list of all in-service and in-situ lines at co-located Open eir exchanges.

3.5.1 Business Planning Information

Open eir will make available the following information about each of its exchanges to allow Operators to undertake business planning activities:

- ✔ exchange names
- ✔ short code identifiers for exchanges
- ✔ full postal addresses of exchanges and / or grid co-ordinates of exchanges
- ✔ PSTN number ranges associated with each exchange
- ✔ number of working lines
- ✔ geographical coverage of each exchange
- ✔ type of MDF (small, medium or large).

This list includes additional items that are not in Open eir's ARO as required by ComReg in Decision Notice D5/01, Decision 5.3.1.

3.5.2 Survey Information Library

It is highly likely that more than one Operator will be interested in the same exchange facility. To assist Operators and to avoid unnecessary duplication of survey activities, Open eir will maintain a library detailing the results of exchange surveys.

The library will reference all Initial and Full Surveys (See Sections 3.7 and 3.8) as well as any other surveys that may be undertaken from time to time for the benefit of Open eir or for other parties.

Open eir will also maintain a listing of its exchange facilities indicating:

- ✔ dates of previous surveys
- ✔ type of surveys undertaken
- ✔ whether a colocation offer was taken up as the result of a survey.

In addition, Open eir will also maintain a list of exchange facilities where surveys have shown that there are restrictions on the provision of colocation space and indicating the nature of the restriction (e.g. MDF space, power limitations, space etc.)

Clearly, Operators should treat this information with caution since the accuracy of the information may eventually deteriorate with time. Therefore, it is not recommended to proceed without full survey.

3.6 Provision of Site Specific Information

Site specific information is provided as part of the Draft Licence. This includes

- ✔ Plans of the exchange buildings
- ✔ Plans of the surrounding campus
- ✔ Location of MDF
- ✔ Location of Equipment
- ✔ Location of Duct route and probable cable chamber

In addition to the generic information, Operators will also be able to request more detailed site specific information from Open eir.

3.6.1 Prerequisites

As per Section 3.3

3.6.2 Site Specific Information Request

To request site specific information, the Operator should complete a Site Specific Information Request Form (SSIR Form) and submit it to the Open eir account manager. A copy of the SSIR Form is attached as Appendix F.

Open eir will check the SSIR Form and ensure that the information is correct. If the information is correct and complete, Open eir will acknowledge the request as having been received and accepted as valid. If the form is not complete or has invalid information, the request will be rejected. The Operator will be informed of the reason(s) for rejection and the order will be terminated.

Orders will be received within the hours of 9am and 5pm, Monday to Friday excluding Irish Public Holidays. For the purposes of SLA compliance, where orders are received outside of these working hours, "the clock" will not start until 9am of the following working day.

3.6.3 Site Specific Information Pack

On receipt of a request from an Operator, Open eir will prepare a Site Information Pack. The information pack will contain copies of Open eir 's standard site and building plans as follows:

- ✔ plans of the exchange buildings (which may be edited to protect confidentiality)
- ✔ plans of the surrounding campus (where these exist)

If the layout of the premises has changed substantially since the plan was made, then Open eir is also required to provide a written commentary explaining the changes.

The AP will estimate space availability at the site based on an assumed Operator requirement of a total of two footprints and 500 MDF terminations. Duct availability for the Operator ' fibre into the cable chamber will also be referenced. This will not preclude an Operator from submitting subsequent orders for that site.

All indications of space availability are based on desk research, and are subject to full survey.

In the event of the AP confirming space is not available, the terms and conditions for site inspection will be those detailed in section 3.16 ("Special Inspection").

If CoLo other than for LLU is requested then MDF terminations are not required.
If required installation of a power meter will also be referenced .

3.7 Initial Survey

3.7.1 Definition

An Initial Survey is a preliminary survey of an exchange to determine the potential of an exchange to support colocation. Initial Surveys will be undertaken by Open eir on receipt of a request from an Operator.

The purpose of the Initial Survey is to give an Operator a quick and cost-effective means of checking the potential of an exchange to support colocation.

This is a desktop survey, usually a site visit is not part of survey.

3.7.2 Prerequisites

As per Section 3.3.

3.7.3 Initial Survey Request

To request an Initial Survey, the Operator should complete an Initial Survey Request form (ISR Form) and submit it to the Open eir account manager.

A copy of the ISR form is attached as Appendix A.

The initial survey request is not an order for co-location and will not result in the reservation of space in the Open eir exchange. However, the Operator needs to indicate the number of terminations they require.

If CoLo for VUA then MDF terminations are not required.

Report Options

When submitting an Initial Survey Request, an Operator will have the option to specify their requirements in terms of:

- ✔ Footprint space
- ✔ MDF space if CoLo for LLU
- ✔ Duct space
- ✔ DC power or AC power
- ✔ Heat dissipation
- ✔ the Operator gets a report that simply specifies whether the request for co-location can be met.

3.7.4 Initial Survey Request Acknowledgement

Open eir will check the ISR Form and ensure that the information is correct. If the information is correct and complete it will acknowledge the request as having been received and accepted as valid. If the form is not complete or has invalid information, the request will not be accepted and returned to the Operator. The Operator will be informed of the reason(s) non acceptance. They will then have 10 working Days to resubmit the order.

Orders will be received within the hours of 9am and 5pm, Monday to Friday excluding Irish Public Holidays. For the purposes of SLA compliance, where orders are received outside of these working hours, "the clock" will not start until 9am of the following working day.

3.7.5 Initial Survey Report

On completion of the Initial Survey, Open eir will prepare an Initial Survey Report. The report will indicate, subject to a full survey the potential of an exchange to support colocation, based on the Operator requirements. If the request cannot be fulfilled, the Initial Survey Report should state explicitly the reasons, the following responses are permissible:

- ✔ "yes - contiguous or non-contiguous space potentially available subject to full survey"
- ✔ "yes - potentially available subject to full survey"
- ✔ "no - insufficient footprint"
- ✔ "no - insufficient MDF space"
- ✔ "no - insufficient footprint and MDF space"
- ✔ "no - insufficient duct space into the cable chamber".
- ✔ "yes - sufficient power"
- ✔ "yes - potentially sufficient power subject to full survey"
- ✔ "no - insufficient power"
- ✔ "no - No desk top information available"
- ✔ "no - insufficient cooling"

For the avoidance of doubt, the first response above will only be provided if the box (requesting knowledge of whether the space is available in a contiguous block) is ticked in the ISR form. If the box is ticked and non-contiguous space is available (subject to full survey) then the second response will be provided. If the box is not ticked and there is available space (subject to full survey) the second response will be provided whether the space is contiguous or not.

Validity of Initial Survey Reports

Operators will normally be expected to respond to an Initial Survey Report within 20 working days of receipt with a request for a Full Survey Report. However, Initial Survey Reports will not time-expire or lapse.

3.8 Full Survey

3.8.1 Definition

A full survey is a detailed survey undertaken by Open air to assess the work that would be required to prepare the Open air exchange facility to provide the serviced accommodation requested by the Operator.

3.8.2 Prerequisites

As per section 3.3 In addition, a Full Survey Request may follow on from the receipt of an Initial Survey Report which indicated that following a full survey the Operator requirements could/may be met. However, Operators have the option to request a Full Survey without first requesting an Initial Survey, however following such a survey and in the absence of ISR the Operator requirements may not be met.

Full Survey Request

To request a Full Survey, the Operator should complete a Full Survey Request form (FSR Form) and submit it to the Open air account manager. As part of the request the Operator needs to indicate the number of terminations they require.

If CoLo for other than LLU then MDF terminations are not required.

Operators have the option to proceed immediately to a Site Offer Request without first receiving a Full Survey Report. To request this option, the appropriate section of the FSR form should be filled in. A copy of the FSR form is attached as Appendix B.

Technical and exchange layout Information on the FSR Form

Operators will need to specify technical information about the equipment that they wish to install on the FSR form. This will include information such as:

- equipment weight
- detailed power requirements (DC Power, or AC Power)
- heat dissipation
- Number of terminations per MDF, if CoLo for LLU
- Order of preference in which footprints are required.

This information is necessary to allow Open eir to assess the suitability of the exchange facility to house the equipment and to allow Open eir to determine the work that would be required to prepare the accommodation for use.

Operators are not required to disclose any information relating to the make, model or functionality of the equipment to be installed. However, all equipment specified must be of a type that has been notified to the industry as per the Equipment Notification process (see Section 4).

3.8.3 Full Survey Request Acknowledgement

Open eir will check the FSR or CFSCSOR³ Form and ensure that the information is correct. If the information is correct and complete it will acknowledge the request as having been received and accepted as valid. If the form is not complete or has invalid information, the request will be rejected. The Operator will be informed of the reason(s) for rejection and the order will be terminated.

Orders will be received within the hours of 9am and 5pm, Monday to Friday excluding Irish Public Holidays. For the purposes of SLA compliance, where orders are received outside of these working hours, "the clock" will not start until 9am of the following working day

3.8.4 Full Survey Report

After completing the survey, Open eir will prepare a Full Survey Report for consideration by the Operator.

The Survey Report will review the suitability of the colocation space against the Operator's requirements and will indicate what work (if any) needs to be undertaken to prepare the accommodation for use by the Operator.

In the event of a rejection based on the Full Survey Report, Open eir will provide a break-down of the reasons for rejection and whether or not a reduced request would be possible E.g.

- No – insufficient footprint – only 1 footprint available
- No – insufficient MDF space – only 800 terminations available

The Survey Report will list the modifications and will provide an indicative costing, with the associated timescales for delivery of the modifications.

Background information on the accommodation shall be provided including:

- Any relevant historical information on the site, ie susceptibility to flooding, lighting strike etc.

The Survey Report should include information on any known maintenance and upgrading work for the exchange (which may be known by the exchange manager at the time of the survey) that will affect the colocation space or access to it during the next 12 months. Such instances might include, but are not limited to:

- Building works to the relevant colocation space
- Other building works which might impact the availability of power and air conditioning facilities or reduce the level of access to the colocation space for a limited period.
- Existing planned upgrades to power and air conditioning equipment

³ Combines Full Survey & Collocation Site Order Requires

-
- ✔ Plans to upgrade the MDF
 - ✔ Building work on campus which may impact the path of the fibre connection from the exchange to the Operator's splicing pit
 - ✔ Closure of the exchange.

Open eir shall be consulted as to knowledge of the above as part of the Full Survey process.

A survey request will not result in reservation of any exchange space.

3.8.5 Progression of CFSSOR

Where the Operator has submitted a CFSSOR, the AP will indicate, within 20 working days of submission of the request, whether a site offer will be issued in respect of that request. Where a site offer will not be issued, the process will end at that point. Where a site offer will be issued, the AP will proceed with preparing the site offer unless instructed otherwise by the Operator⁴.

Validity of Full Survey Report

Operators will normally be expected to respond to a Full Survey Report within 20 working days of receipt with a request for a Site Offer. However, Full Survey Reports will not time-expire or lapse but space will not be reserved.

3.9 Site Offer

3.9.1 Definition

A Site Offer is an offer by Open eir to the Operator for the preparation of the accommodation to support the Operator's requirements.

3.9.2 Prerequisites

As per section 3.3. In addition, a Full Survey Report is a prerequisite for a Site Offer request. However, Operators may make a combined request for a Full Survey and Site Offer.

3.9.3 Site Offer Request

To request a Site Offer for a colocation space in an Open eir exchange facility, the Operator will complete a Site Offer Request form (SOR form) and submit it to Open eir.

A copy of the Site Offer Request Form is attached as Appendix B.

3.9.4 Site Offer Request Acknowledgement

Open eir will check the CSOR4 Form and ensure that the information is correct and that the colocation space has not been allocated since the Full Survey report was completed. If the information is correct and complete it will acknowledge the request as having been received and accepted as valid providing a target delivery date. If the form is not complete or has invalid information, the request will be rejected. The Operator will be informed of the reason(s) for rejection and the order will be terminated.

⁴ Collocation Site Offer Request

Orders will be received within the hours of 9am and 5pm, Monday to Friday excluding Irish Public Holidays. For the purposes of SLA compliance, where orders are received outside of these working hours, "the clock" will not start until 9am of the following working day.

3.9.5 Site Offer

Open eir will review the Full Survey Report and prepare a Site Offer for the Operator.

The Site Offer will contain:

- ✔ A covering letter summarising the key points of the Offer
- ✔ a draft project plan which will include an Estimated Provisioning Duration
- ✔ a License Agreement
- ✔ an exchange location map and exchange building map. The latter will show the location of the Operator footprints within the exchange floor area.
- ✔ Location of power meter
- ✔ The fibre distance, from the Operators footprint to the Open eir nominated manhole.
- ✔ The subduct length required for the exchange.
- ✔ The name and contact number of the Open eir Project Manager.

For clarity and for the avoidance of disputes, the Site Offer will itemise each of the main elements of the work required.

Open eir proposed the following footprint identification scheme

Exchange code footprint number

For example, where an Operator has two footprints in Dame Court, they may be identified as

- ✔ DCT_OPERATOR A_001
- ✔ DCT_OPREATOR A_002

This information will be supplied at offer stage and further discussed at the kick-off meeting held after signing of the Licence Agreement.

Validity of Space Reservation

On production of the Site Offer, the exchange floor space covered by the offer shall be reserved for the Operator for a period of three months from date of the offer. This reservation is renewable by mutual agreement. If the reservation is not renewed, it will lapse.

Space reservation will automatically lapse where the Site Offer is rejected.

Validity of Site Offer

The validity of the prices and timescales quoted in the Site Offer will be similar to the validity of those quoted to Open eir by its own contractors. As a result, the Site Offer will be valid for a period of three calendar months from the date of the Offer, on the understanding that the prices and timescales may vary if the Offer is not accepted within the Offer period.

The Site Offer will lapse in the event that:

- ✔ It is rejected by the Operator
- ✔ The space reservation lapses.

3.9.6 Order

To accept the Site Offer prepared by Open eir, the Operator will sign and return the Licence Agreement, together with any relevant payment, to the Open eir account manager.

3.10 Site Preparation

On receipt of a signed Licence Agreement and relevant payment from the Operator, Open eir and the Operator will agree a project to prepare the serviced accommodation for the Operator.

The project plan will contain but not limited to the following tasks:

- ✔ Kick off meeting
- ✔ Manhole break in
- ✔ Delivery date of fibre
- ✔ Delivery date of blocks if required
- ✔ Fibre cable pull
- ✔ Install MDF blocks if required
- ✔ AC power and lighting
- ✔ DC power or AC power
- ✔ Power meter installation
- ✔ Racking and cable containment
- ✔ Earth Window installation
- ✔ PSTN line installation if required

Note: delays on agreed dates in the project plan will affect the dependencies of the delayed task.

3.10.1 Kick Off Meeting

At the start of the project, Open eir will arrange an on-site meeting with the Operator to discuss the planned works, normally this would be at the exchange site however if this cannot be arranged in a timely manner the meeting can take place elsewhere or via a conference call.

This meeting will discuss:

- ✔ provisioning of the requested serviced accommodation
- ✔ agreed dates for the Windows of Inspection
- ✔ installation of the Operator's equipment.
- ✔ agree list of deliverables that both parties will sign off at the end of the process

Open eir will endeavour to permit the Operator to commence its equipment installation as soon as is practicable after the KO meeting.

Project Liaison / Stating

Open eir will nominate a project manager to manage each Site Preparation project. The project manager will liaise with the Operator's nominated contact(s) and will be responsible to:

- ✔ provide regular updates on the progress of the project
- ✔ notify the Operator of any delays that are likely to affect the Schedule Completion Date
- ✔ notify the Operator of any unforeseen requirements that may affect the cost of the project.

Where agreement is not reached within three working days, either party may refer the matter to the dispute resolution procedure detailed in the Licence Agreement.

Ongoing project review meetings will take place between the parties to ensure that implementation is on track and to resolve any difficulties. The frequency of these meetings will be determined bi-laterally.

3.10.2 Formal Acceptance

On completion of the Site Preparation project, Open eir will arrange a Site Inspection. The purpose of this meeting is for the Operator to certify that the Site Preparation Works are completed. At this date, any remaining Site Preparation Fee monies due will be invoiced to the Operator.

The meeting will normally be attended by:

- ✔ The Operator's project manager or Clerk of Works,
- ✔ Open eir's nominated representatives,

The outcome of the meeting will be the signing of a certificate (see Appendix J) by both parties stating that the site preparation works have been completed to the satisfaction of both parties.

In the event that problems are identified with the serviced footprints which have arisen, the Operator's and Open eir's project managers will attempt to agree a resolution. Where agreement is not reached within three working days of the meeting, then the matter may follow the dispute resolution procedure detailed in the Licence Agreement.

The general condition of the room at hand-over (e.g. repair, cleanliness, and access) shall form the benchmark against which the ongoing condition of the room is compared.

The Operator is required to have installed and powered its equipment within twelve months of formal acceptance. If the Operator has not installed any equipment and it is not drawing power within this timeframe, Open eir shall discuss the situation with the operator and notify ComReg should it suspect that colocation space is being hoarded. Open eir shall also notify industry that space may be available at that exchange. Once the installation has commenced on site all works must be completed within the three-month time frame.

3.11 Equipment Installation

The Operator will install its equipment on the dates agreed in the Site Preparation project plan, or as subsequently agreed bi-laterally.

3.11.1 Site Access for Equipment Installation

Escorted access for the Operator (or its contractors) shall be arranged by following the Planned Access Process for Physical Change.

All equipment installed shall be accredited as described in the equipment notification and verification process, see Section 4.

3.11.2 Installation Personnel

The Operator or its nominated contractor(s) which undertakes the equipment installation will be accredited as defined in Access process (See Section 5).

3.11.3 Permissible Equipment

All equipment installed by the Operator will be of types that have been previously notified as per the Equipment Notification process (see Section 4).

There is no obligation on the Operator to notify Open eir of the particular type of equipment that is installed at any particular exchange facility, although a verification process may take place as equipment is taken onto a site (see Section 4).

3.11.4 Health and Safety Requirements

Operators and their contractors must ensure that they work in a safe manner that complies with current health and safety legislation and which ensures the health and safety of their own personnel as well as that of Open eir employees.

Operators and their contractors must comply with Open eir's health and safety requirements as described in Appendix 3 to Service Schedule 101 of Open eir's ARO

3.11.5 Final Site Meeting

On completion of the equipment installation, prior to power-up and commissioning, Open eir will arrange a final site meeting. The purpose of this meeting is to conduct a health and safety inspection of the installation.

The meeting will normally be attended by:

- ✔ the Operator's Representative(s)
- ✔ Open eir's nominated Representative(s)

At the meeting, Open eir will inspect the installation to ensure that it has not introduced any safety hazards.

The Operator shall provide a certificate, signed by the **Operator's** representative, certifying that the work has been completed to a satisfactory health and safety standard. A sample of such a certificate is attached at Appendix N.

3.12 CoLo CEI Backhaul Connection

Where an Operator has availed of open eir Duct Access product and has achieved 'UUB box/chamber access accreditation' then that Operator may request to install their passive equipment in a suitable UUB and connect the backhaul cable at that UUB, subject to open eir agreement.

The backhaul cable is ordered as a 'CoLo CEI Backhaul Connection' as part of the Physical Co-Location product, whereas the equipment in the UUB is licenced and chargeable as part of the Duct Access product

The Operator should submit a request for this service as part of the Site Preparation using the template in Appendix T and email it to their open eir Account Manager. Up-front charges will apply.

3.13 CoLo Rack Interconnect Tie Cable / Resource sharing

An Operator may request a “CoLo Rack Interconnect Tie Cable”. This allows an Operator to have their licenced Serviced Exchange Footprint connected to a Serviced Exchange Footprint licenced to a different Operator.

The tie fibre cable will be provided, installed and maintained by open eir, will be managed via a central tie cable management point, and will be terminated on a patch panel provided by the Operator in their rack. The Operator must advise the requested patch panel connector types. A quote for this tie cable will be prepared before work commences. A circuit reference number will be provided.

An Operator may opt to use ‘CoLo Resource Sharing’, whereby an Operator can arrange to ‘share’ backhaul with another CoLo licenced Operator. To avail of resource sharing an Operator must apply for a “CoLo Rack Interconnect Tie Cable” between the two footprints. Only equipment owned by an Operator can be installed in the Serviced Exchange Footprint licenced to that Operator. The Operator should advise their open eir Account Manager by email if this is being planned.

The Operator should submit an order for this Tie Cable service using the template in the Appendix U and email it to their open eir Account Manager. Up-front and annual rental charges will apply,

3.14 Wholesale Ethernet Interconnect Link (WEIL) and Wholesale Symmetrical Ethernet Access (WSEA) In-Building Handover (IBH)⁵

A WEIL / WSEA IBH order will provide connectivity from the Open eir network to an Operator’s nominated In-Building Handover (i.e. Co-Location Rack) located within an Open eir exchange.

The WEIL physical connectivity will require preparation and installation of Open eir fibre (terminated on an Open eir ODF), and an Operator fibre (installed by Open eir) between an Operator Co-Location rack and the Open eir ODF, within the same Open eir exchange as the Open eir NGN Node (as depicted in the following diagram)

⁵ COLO and backhaul delivery will be project managed

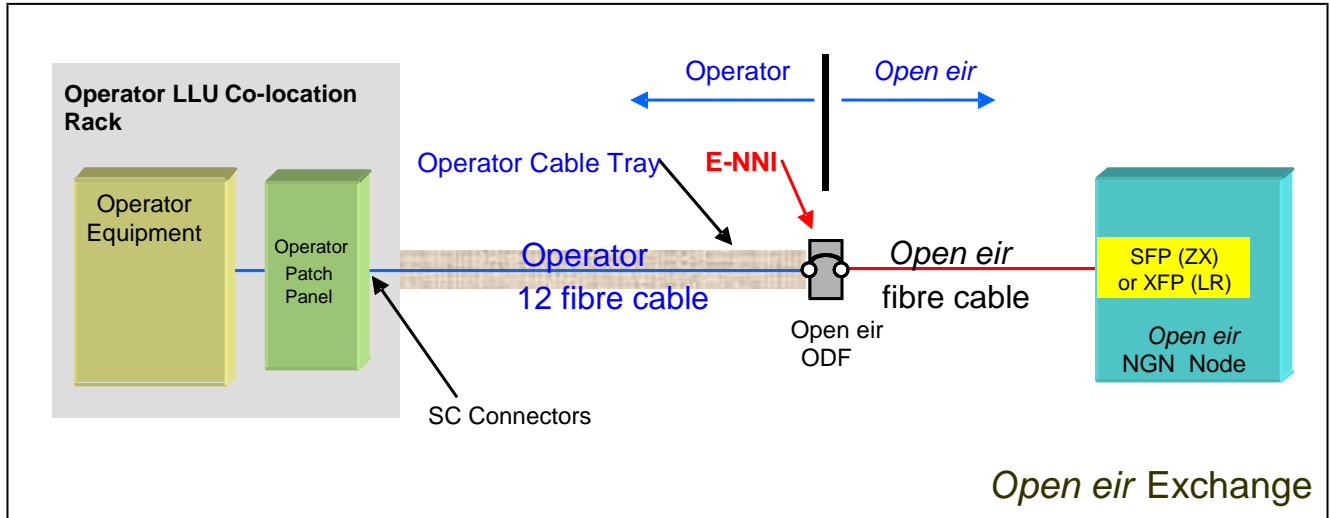

Figure 1: Wholesale Ethernet Interconnect Link (WEIL) In-Building Handover

The WSEA IBH physical connectivity will require preparation and installation of Open eir fibre (terminated on an Open eir ODF) with another Open eir fibre installed between an Operator Co-Location rack and the Open eir ODF, within the same Open eir exchange as the Open eir NGN Node (as depicted in the following diagram).

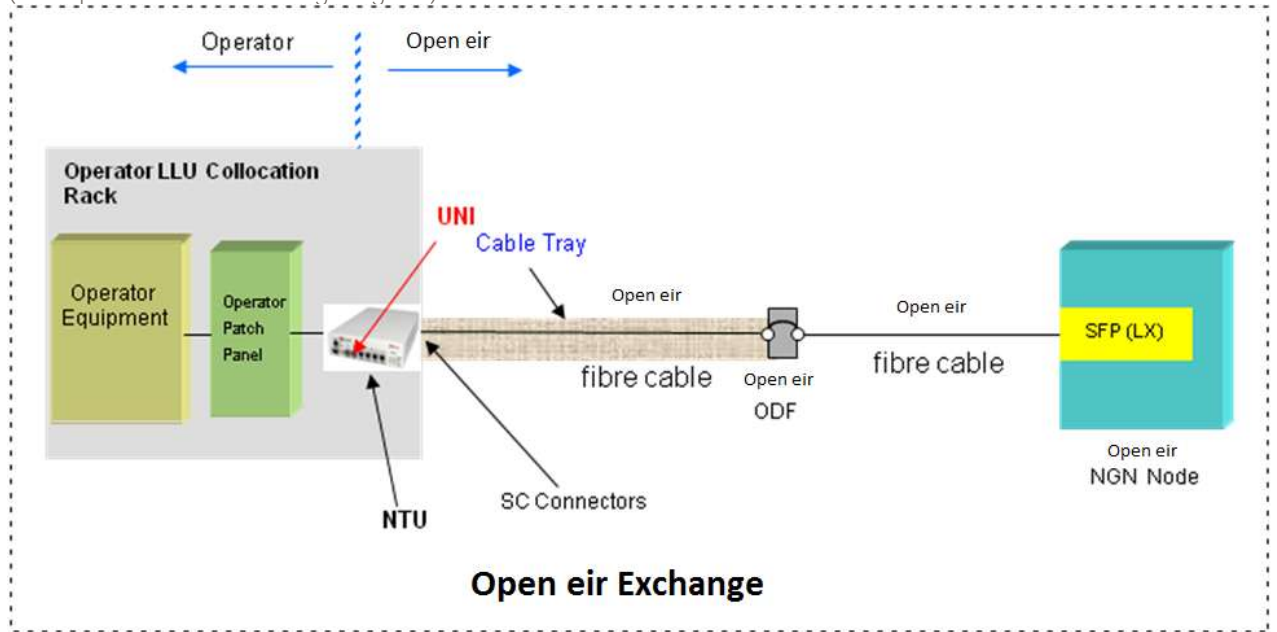

Figure 2: Wholesale Symmetrical Ethernet Access (WSEA) In-Building Handover

There are two stages in the provision of WEIL / WSEA-IBH:

- Quote for Infrastructure (QIB)
- Provide Infrastructure Build (PIB)

3.14.1 Quote for Infrastructure (QIB)

Before placing the order on the UG an Operator must have the Co-location footprint for the purposes of LLU in place in compliance with the Process Manual for Open eir Physical Co-location Service (i.e.

signed Co-Location Licence). Alternatively an Operator may have the Co-location footprint for the purposes of NGA VUA or for Interconnect or for CEI.

The Operator shall place a Quote Infrastructure Build (QIB) order on the UG for Open eir to undertake to assess the work that is required to prepare the Open eir exchange facility for an In-Building Handover and provide a quotation for an Operator. (As per Appendix S)

The QIB order will provide a quote for the Operator identifying what is required to provide fibre cable to the Operator co-location space to facilitate delivery of a WEIL / WSEA IBH circuit.

QIB orders shall be completed within 15 working days. The target is 100% of QIB orders shall be completed within this timeframe.

3.14.2 Provide Infrastructure Build (PIB)

On receipt of the quotation the Operator shall either accept or reject the quotation. If Operator decides to accept the quotation they proceed to place a Provide

Infrastructure Build (PIB) via the UG, having signed Deed of Variation (DoV) to the existing Co-Location Licence.

On receipt of a valid PIB order, Open eir will deliver the infrastructure and notify the operator.

3.15 Grouping of Requests

In some cases an Operator will need to be able to view the results from several Initial Surveys, Full Surveys or Site Offers before being able to make a balanced decision on the viability of a particular business plan.

Therefore, Operators will be permitted to submit several requests as a group.

Open eir will endeavour to meet these grouped requests, however all orders will be treated on a "First Come, First Served" basis.

3.16 Forecasting of Demand and Provision of Resources

Operators shall work closely with Open eir to ensure that sufficient notice is provided of upcoming surveys in order to match expectations to resources.

3.17 Service Levels

This section defines the target delivery times that Open eir should meet for the provision of Initial Survey Reports, Full Survey Reports and Site Offers. No target is defined for Site Preparation since clearly time scales will vary considerably dependant on the amount of work to be undertaken.

These targets apply to the requests detailed in this document. The timelines will be the same as those applicable in the relevant SLA.

| Activity | Target |
|-----------------------------------|--|
| Provision of generic information | 4 working days after signature of an NDA by the Operator |
| Site Specific Information Request | Acknowledgement: 1 working day after date of despatch of SSIR form by the Operator to the AP |

| | |
|-------------------------------------|---|
| | Delivery of report: 10 working days after date of despatch of SSIR form by the Operator to the AP |
| Initial Survey | Acknowledgement: 1 working day after date of despatch of ISR form by the Operator to the AP |
| | Delivery of report: 10 working days after date of despatch of ISR form by the Operator to the AP |
| Full Survey | Acknowledgement: 1 working day after date of despatch of FSR form by the Operator to the AP |
| | Delivery of report: 10 working days after date of despatch of FSR form by the Operator to the AP |
| Site Offer | Acknowledgement: 1 working day after date of despatch of Site Offer request form by the Operator to the AP |
| | Delivery of offer (after date of despatch of Site Offer request form by the Operator to the AP): 10 working days |
| Combined Full Survey and Site Offer | Acknowledgement: 1 working day after date of despatch of CFSSOR by the Operator to the AP |
| | Delivery of offer (after date of despatch of CFSCSOR form by the Operator to the AP): 20 working days where outside tenders are required |
| Site Preparation | As per agreed Project Plan. Any changes will be captured by change control within the Project Plan |
| Expansion of Capacity Request | Acknowledgement: 1 working day after date of despatch of EOC by the Operator to the AP |
| | Delivery of offer (after date of despatch of EOC form by the Operator to the AP): If the request is with in 3 months of the original licenses being signed for the site requested 10 working days of receipt. If the request is outside the 3 months of the original licenses being signed for the requested site 15 working days of receipt. |

Table 2: Service Provisioning Activity Target Timelines

3.18 Cessation

Cessation constitutes Physical Change and should follow the appropriate process.

When the Operator has removed the relevant equipment and all cabling, including fibre, a site inspection will be conducted by Open eir to ensure that the site has been restored to its pre-co-location condition, and that work is completed from a health and safety perspective.

Open eir will conduct this inspection within five working days after written confirmation from the Operator that the equipment has been removed, and will notify the Operator of its findings within a further three working days. Billing will cease on confirmation by Open eir that the cessation work is satisfactory. On the Access Request Form, the box for equipment removal should be selected, as per the Access process (See Section 5).

All ULMP and Line Sharing services must be ceased before the Access Request Form is submitted.

The Operator is responsible for making good the condition of the premises as may be required by the Licence.

3.19 Special Inspection

Operators have the right to request access to any Open eir exchange facility to undertake an inspection where:

- the Operator is not satisfied by Open eir's offer for Physical Collocation (queries relating the cost of works required to prepare the accommodation)
- Open eir has refused a collocation request on whatever grounds
- Open eir has indicated in response to an ISR, FSR or combined FSR / Site Offer request, that physical collocation may be available.

Special Inspection requests should be submitted in writing to the Open eir account manager. Open eir will provide escorted access to the exchange facility.

Special Inspection requests must specify:

- the grounds on which the inspection is requested
- the number of Operator representatives attending, and their names and respective roles within the Operator organisation
- Open eir will also supply list of attendees prior to the inspection.

The inspection will consist of:

- where collocation has been refused because of lack of floor space, escorted access to the exchange room
- where collocation has been refused because of lack of MDF space, escorted access to the MDF room
- where collocation has been refused because of lack of duct space into the cable chamber, escorted access to the cable chamber.

The following conditions must be observed:

- The use of cameras, or any electronic recording or measuring equipment is not permitted while in the exchange building.
- Operator will be permitted to take relevant notes.
- All attendees will be required to wear identification. For the purpose of the site inspection, the Operator attendees need not be registered.
- Any queries that may arise during or after the inspection will be submitted to Open eir in writing after the visit.

- Informal questioning will be permitted however the written response by Open eir to the Operator query will represent Open eir's **formal answer to the Operator query**.
- To avoid potential delays, all attendees will meet at a neutral location before proceeding to the Site as a group.

Requests should normally be granted within 10 working days or at a later date if specified by the Operator. ComReg may be informed of such inspections and can be requested to attend by either party.

3.20 Right of Appeal

Disputes between Operators and Open eir over the availability or provision of Physical Collocation should normally be resolved by negotiation between the parties involved.

Exceptionally, both Open eir and the Operator have the right to appeal to ComReg for an adjudication.

3.21 Equipment Footprints

Requests for colocation space should be made in terms of the quantity of standard equipment "footprints" as defined by Open eir in Service Schedule 101.

3.22 Expansion of Capacity Request

3.22.1 Definition

Where an Operator is currently licensed to physically co-locate within an Open eir exchange, and co-location has taken place, they must submit an expansion of capacity request where the installation of any equipment results in any of the following:

Additions or changes to floor space, ladder rack space, cable tray space, increase in DC power usage, OPE's usage, or heat dissipation.

3.22.2 Prerequisites

As per section 3.3. In addition, an expansion request application can only be made after a site offer has been accepted and works completed.

An expansion request application must be made if any additional equipment is to be installed after the date of completion of the previous installation.

3.22.3 Expansion of Capacity Request

To request a Expansion of Capacity, the Operator should complete a Expansion of Capacity (EOC Form) and submit it to the Open eir account manager.

At managed MDFs, an expansion of capacity request may be submitted for specified Sub-Frame Groups to cater for uneven fill of Operator terminations. The survey results will apply to the specified sub-frame groups only and will not take alternative MDF space into account.

A copy of the EOC form is attached as Appendix P.

Technical and exchange layout Information on the EOC Form

Operators will need to specify technical information about the equipment that they wish to install on the EOC form. This will include information such as:

- Additional floor space (in multiples of 600mmx400mm footprints)
- Additional power requirements
- Number of MDF Terminations
- Tie cable configuration
- Order of preference in which footprints are required.
- Additional heat dissipation, if applicable

This information is necessary to allow Open eir to assess the suitability of the exchange facility to meet the expansion request and to allow Open eir to determine the work that would be required to prepare the accommodation for use.

Expansion of Capacity Request Acknowledgement

Open eir will check the EOC⁶ Form and ensure that the information is correct. If the information is correct and complete, it will acknowledge the request as having been received and accepted as valid. If the form is not complete or has invalid information, the request will be rejected. The Operator will be informed of the reason(s) in detail for rejection and the order will be terminated.

Orders will be received within the hours of 9am and 5pm, Monday to Friday excluding Irish Public Holidays. For the purposes of SLA compliance, "the clock" will not start until 9am of the following working day.

The Survey Report will review the suitability of the expansion request against the Operator's requirements and will indicate what work (if any) needs to be undertaken to prepare the accommodation for use by the Operator.

The Survey Report will list the modifications and will provide an indicative costing, with the associated time scales for delivery of the modifications.

Progression of EOC

Where the Operator has submitted an EOC, the AP will provide, within 15 working days of submission of the request, an EOC survey report. This will indicate if the application is being accepted or rejected the detailed reasons.

When the report has been accepted by the Operator.

Where Open eir are required to undertake preparation works, as defined under the project plan the Operator will be notified when to proceed with the EOC.

Where no intervention is required by Open eir the Operator will make a request via the planned access request process to undertake the work.

The Operator will notify Open eir when the is completed and sign off will be agreed

⁶ Expansion of Capacity Form

Validity of Expansion of Capacity Report

Operators will normally be expected to respond to an Expansion of capacity within 15 days.

EOC reports will be valid for a 3 month period. However, if Open eir or another operator seeks the space then the Operator will be notified and must accept the site offer within 4 weeks or the space will be re-allocated.

Final site Inspection of Expansion

A final site inspection will take place to ensure that the expansion has been carried out to both parties' satisfaction.

4. Equipment Notification

4.1 Equipment Requirements

All operators shall provide a statement of conformance, identifying the manufacturer's quoted standards for an item of equipment installed in the colocation suite. Standards shall be provided which cover the following areas:

- ✔ Health and Safety
- ✔ Conformance to the Spectrum Mask
- ✔ Electromagnetic emissions
- ✔ Electrical power interface : note line side electrical interface characteristics are dealt with in the definition of the Spectrum Mask.

4.2 Notification

4.2.1 Information

To register a new type of equipment, the Operator should submit an Equipment Notification Request form (ENR Form) to the Open eir account manager.#

A copy of the form is attached as Appendix E.

The level of equipment notification shall be:

- ✔ Maker
- ✔ Model
- ✔ Set of standards which are quoted by the manufacturer for the product, in the areas identified in Section 4.1 above.

Provision of information for a specific system is deemed to act as notification of all of the manufacturer's components of the notified system, consequently there is no burden on any operator to add all of the component parts of a system to a list.

4.2.2 Supporting Documentation

Operator's will not normally be required to submit supporting documentation to prove that their equipment meets the current technical requirements for colocation equipment, however, the ENR form includes a declaration that the equipment meets all the necessary requirements.

4.3 Collocation Equipment Register

Open air will maintain the Collocation Equipment Register on behalf of the industry.

The Register will be made available to Operators at Open air's secure web-site, or via e-mail or some other method, which is fit for purpose.

The register will list the following information for all registered equipment:

- manufacturer
- model name/number
- date of registration.

The template for the Register is attached (Appendix L).

4.4 Equipment Registration

The Open air account manager will acknowledge the Equipment Notification within 5 working days of receipt.

At this stage, the equipment will be added to the Register.

It is incumbent on Open air to ensure that all exchanges have immediate access to the most up to date valid equipment list.

4.5 Installation of Equipment

Once a particular equipment type has been registered all Operators and Open air will be free to deploy the equipment in collocation spaces.

When equipment is brought onto an Open air site, Open air is free to check that the equipment is from a manufacturer and product included on the register.

4.5.1 Over Voltage Protection (OVP)

When installing equipment Operators are advised to install Over Voltage Protection (OVP).

However, Operators are free to choose whether or not to implement OVP on their equipment.

Operators should be aware of the risk and liability that they carry in respect of damage to their own equipment and damage to third party equipment by choosing not to install OVP on their equipment, should an incident occur.

Where Operators opt to self supply DC power, then all electrical installations must conform to the Electro Technical Council of Ireland (ETCI) current regulations. The installation of any batteries must conform to EN 50272 (Requirements for Stationary Batteries and Installations) and EN70079 (ATEX Directive) ; battery maintenance and replacement in accordance with IEEE450 or IEEE1188.

4.6 Objections

After a new piece of equipment is added to the Equipment Register, Open air and Operator's will have 20 working days to raise any objections to the equipment being added to the list.

Lack of approvals to relevant technical standards (covering the areas identified in Section 4.1) will be the only grounds for objection. Whilst the objection is pending, the equipment shall remain active in the field, subject to considerations for health and safety.

In the event of an objection being raised, the objection should normally be dealt with informally between the two parties involved.

If necessary, the matter can be referred to the dispute procedure detailed in the Access Agreement.

4.7 Non-Compliant Equipment

If Open air or an Operator has reason to believe that a type of equipment that has been registered does not conform to the technical standards that were current when it was introduced it is entitled ask ComReg to investigate.

If ComReg finds that the equipment does not comply with the technical standards it can rule that the equipment should be withdrawn from service if it can be shown to:

- ▶ be unsafe in any respect
- ▶ cause significant interference to other users of the Open air access network.

4.8 Notification of Open air Equipment

The rules concerning equipment notification also apply to equipment installed by Open air in its exchange facilities.

The rules will not apply retrospectively.

5. Access

5.1 Accreditation

Before being given access to an Open air colocation facility, an Operator will be required to undergo an accreditation process and ESKT - Open air on Site Knowledge Test. The purpose of the accreditation is primarily to ensure:

- ▶ the health and safety of all personnel who work at the Open air exchange facility
- ▶ the security of the Open air exchange facility.

Accreditation will be both on a corporate basis and at individual personnel level. Individual staff can be accredited for either Escorted or Unescorted Access. There are two parts to the accreditation process: notification and training.

5.1.1 Notification

Third party Liability Insurance

Open air will publish its requirement in respect of third party liability insurance. All Operators will be required to submit documentary evidence of their compliance with this requirement on an annual basis.

Safety Policy Statement

The Operator is required to submit a copy of their Safety Policy Statement and on an annual basis.

5.1.2 Open eir Briefing

A representative of each Operator will be required to attend a briefing provided by Open eir, which will cover the following topics:

- ✔ Open eir access and security procedures for colocation facilities
- ✔ ESKT
- ✔ Open eir's general health and safety requirements for Operator's co-locating equipment in Open eir exchanges.

5.1.3 Use of Contractors

Operators will be permitted to use contractors to undertake work on the Operator's equipment in Open eir exchange facilities on their behalf.

Open eir will not accredit each contractor, however all contractors working on behalf of the Operator must be registered.

The Operator will be responsible for ensuring that its contractors and employees adhere to Open eir's health and safety and access security requirements. All contractor staff working at Open eir premises will be viewed by Open eir as the Operator staff and any breach caused by such contractor staff will be viewed as a breach by the Operator.

5.1.4 Escorted Access Registration

Before any Operator staff (including their contractors) can access an Open eir exchange, they must be individually registered using the Access Registration Form in Appendix M.

Operator staff must be registered at least five working days prior to access.

On submission of an Access Registration Form, the AP will acknowledge receipt of the Form within two working days. The AP will then either accept or reject the Form within five working days of acknowledgement.

The Form will be rejected where it is incomplete or inaccurate. The Operator will then be required to resubmit the Form.

Where the AP accepts the Form, it will register the individual.

Unregistered Operator staff (including their contractors) will not be permitted into an exchange.

Once registered, Operator staffs are thereby registered for all other sites for which the Operator holds a valid Licence Agreement for Physical Co-location.

5.1.5 Unescorted Access Accredited Rights - for employees / contractors of accredited Operator's

As with the corporate accreditation process the Operators Staff (including their contractors) must be individually accredited to be given "Accredited Access Rights" for Unescorted Access. This can only commence after the company has completed the "Probation Period" of not less than 6 months from issue of first licence. The applicant should use the form attached in appendix M and select the "Accredited Access Rights" option.

Operator staff with unescorted Access Rights are only permitted to undertake works, which are designated as “Non Material Change”.

On submission of an Access Registration Form, the AP will acknowledge receipt of the Form within two working days. The AP will then either accept or reject the Form within five working days of acknowledgement.

The Form will be rejected where it is incomplete or inaccurate. The Operator will then be required to resubmit the Form.

Where the AP accepts the Form, it will arrange for the ESKT to be conducted and following successful completion of the ESKT, the AP will register the individual.

On completion of the accreditation process applicants ENSUP card will be activated for the site or sites requested for a period of 12 months.

The Operator will be required on an annual basis to re accredit all staff members who wish to have access to an Open eir colocation area. The Operator must maintain a register of all accredited individuals and inform Open eir of lost / stolen cards and return cards when an employee or contractors no longer works for the Operator.

Unaccompanied access is available at any time to buildings where Open eir have electronic access control in place and where the Operator holds a licence and the exchange is signed off for CoLO for LLU or VUA or Interconnect or CEI. Certain sites, such as ones that are not covered by electronic access, may be available during work hours only.

If entry to an Open eir exchange site is gained using a card allocated to any user, then the user will be deemed responsible for such entry and any actions undertaken during this entry period.

| | |
|---|--|
| Un Planned Non Material Change Access Hours | E-mail in advance of Operators Staff entering on to Open eir site to Open eir. carrierservices@openeir.ie |
| 09:00 to 18:00 | 2 hours – Consecutive |

Table 3: Time lines for notification for unescorted access.

5.2 Physical / Unforeseen Physical Change

5.2.1 Physical Change

When requesting access to do Physical Change (as defined in the Licence Agreement) the Operator will:

- Submit a Schedule of Work and Method Statement to Open eir for approval. The Schedule of Work should include relevant plans and specifications for the work to be carried out, The Methods Statement should include the sequence of work to be carried out, and the working practices to be employed.
- During a kick off meeting Open eir may notify an Operator that a particular method statement and risk assessment maybe required for certain works to cover site specific risks which are identified at the KO meeting.
- Open eir will accept or reject this application within five working days. Upon Open eir approval of both documents, the Operator then follows the Planned Access Request process.

Only the Planned Access process can be used for Physical Change.

5.2.2 Unforeseen Physical Change

When requesting access to do Unforeseen Physical Change (as defined in the Licence Agreement), the Operator may use either the Planned or Unplanned Access processes.

A precondition of this process is that the Operator has already submitted a Methods Statement for the work to be carried out. Should an Operator submit an Access Request for work for which Open eir has no Methods Statement, that request will be rejected. The Operator must follow the process for Physical Change in this instance.

A generic Methods Statement will generally cover Unforeseen Physical Change in all exchanges in which the Operator is co-locating. Where site specific conditions dictate otherwise, Open eir will advise the Operator.

5.3 Access Request

When an Operator requires access, Operator will contact the AP to place its request for access, using the Notification of Access (NA) Form provided in Appendix I.

Forms will be sent by e-mail to the AP and will include such details as:

- ✔ the location
- ✔ date and time at which access is required
- ✔ the booked⁷ duration of the access visit
- ✔ a contact number of the person in charge of works on site
- ✔ The name(s) of the Operator representative(s). In the case of planned access, where this is not known at the time of the request, the name(s) should be provided to the AP e-mail 48 hours before access.

Open eir will use best endeavours to provide escorts past the booked time, should the Operator request it. Operators will be charged for the booked time or the actual time, whichever is the longer. Where access is requested by more than one operator to the same site at the same time access will be provided on first come first served basis should it prove unsafe to allow the 2 or more simultaneous access requests for material work to proceed at any site.

5.3.1 Planned Access Request

Where an Operator' request is for Planned Access, the following process shall apply:

- ✔ The Operator sends a Notification of Access form to the AP co-locations operations manager (COM)
- ✔ The COM confirms he has an approved Methods Statement for the work to be carried out
- ✔ The COM acknowledges the form by either accepting or rejecting it
- ✔ Where the request is accepted, the AP returns the access request form acknowledging the access is either as requested or with whatever changes are required.
- ✔ Where the request is rejected, or changed the reason(s) for rejection or change will be given.

- ✔ The Operator and AP staff meet at the designated site at the designated date and time

The timelines for this process are defined in Table 5 in section 5.4.1.

5.3.2 Unplanned Access Request

An Unplanned Access Request may only be submitted in the following situations:

- ✔ In case of an Emergency
- ✔ Where the Operator requires access in order to investigate a service affecting fault or service affecting interference where other operators' equipment is involved.

Where an Operator' request is for Unplanned Access during normal hours, the following process shall apply:

- ✔ The Operator sends a Notification of Access form by email to the COM
- ✔ The COM will acknowledge the form either accepting or rejecting it
- ✔ Where the request is accepted, the AP returns the access request form for that request.
- ✔ Where the request is rejected, the reason(s) for rejection will be given
- ✔ The Operator and AP staff meet at the designated site at the designated date and time
- ✔ Outside these times emergency access procedures must be used.

N.B. This process applies to requests received for emergency access after 17:00 and before 09:00 on weekdays and all weekends and bank holidays.

The Operator requesting access sends an email request to the OLO desk (olodesk@openeir.ie). The request must include a completed form for access.

The Operator requesting access rings Open eir on the Operator number (01-7017901) to inform them that a request has been sent by mail.

The technician in the S.A.C. dealing with the call will check the mail received and ensure that all details are correct and that sufficient information is given to enable the S.A.C. to determine whom best to call. The CNO-FT should be given the name and contact details of Operator personnel attending on site.

On validating the request Open eir will contact the Operator personnel to organise access.

On conclusion of the visit, both the Operator and AP staff will sign a Chargeable Form. A copy of this form will be retained by both parties. This forms the basis for the billing of the AS

The timelines for this process are defined in Table 6 in section 5.4.2.

The Operator will issue the AP with a unique reference number that will identify the access request and which will be referenced in billing information.

5.3.3 Unescorted Access Requests

An Operator wish to access an Open eir exchange facility unescorted may do so under the following conditions

- ✔ They are accessing a licensed site signed off for CoLo for LLU or VUA or Interconnect or CEI
- ✔ They have been accredited to do so
- ✔ The works to be carried out are classified as “Non Material Change” works, which is limited to fault management, routine maintenance.

Where an Operator’ request is for Unescorted Access, the following process shall apply:

- ✔ Operators shall notify Open eir via email to carrierservices@openeir.ie using the attached form in appendix Q.
- ✔ The subject title on the mail must read “Unescorted Access Request + Operator Name”
- ✔ No formal acknowledgement of receipt will be given.
- ✔ The timelines for this process are defined in Table 7 in section 5.5.3

5.3.4 Special Access Requirements

Operators shall discuss requirements for specialised access with Open eir, to facilitate its provision at site. Such special requirements include, but are not limited to:

- ✔ Method of delivery of equipment
- ✔ Special access requirements
- ✔ Way-leaves

All special access requirements must be identified in the relevant methods statement.

5.3.5 Changes to Access Requests

If it becomes necessary for an Operator to reschedule or cancel an Access Request, the Operator should make contact with the COM at the earliest opportunity.

If the change is made within four working hours of the scheduled visit then Open eir will be entitled to charge for the visit.

5.4 Access Times

Open eir will provide Operators with access to their equipment at any time. Although most access visits are expected to take place during normal office hours on week-days (Standard hours 09:00 to 16:00) excluding bank holidays. Access outside these hours will be available but at a higher charge. Unescorted access is permitted from 9am – 6pm (Monday – Friday, excluding public holidays).

Access Times are specified in Table 4.

| | Time | Days |
|--|------|------|
|--|------|------|



| | | |
|-------------------------|-----------------|---|
| Standard Hours | 0900 to 1600 | Monday to Friday Excluding public holidays |
| Outside Standard Hours | all other times | |
| Unescorted Access Hours | 0900 to 1800 | Monday to Friday Excluding public holidays |

Table 4: Access Times

Note Operators will need to vacate the premises at 1600 if access is being provided as “Standard Hours”.

5.5 Access Lead Times

5.5.1 Planned Access

In most cases access requests will be for routine activities that can be planned in advance. In this case, the Operator should submit a Planned Access request. Table 5 lists the minimum lead times for Planned Access.

| | |
|------------------------|--|
| Standard Hours | Acknowledgement - the AP will accept or reject the request for access 1 working day from date of despatch of Notification of Access form by the Operator to the AP |
| | Minimum notice period: 3 working days from date of despatch of Notification of Access form by the Operator to the AP |
| Outside Standard Hours | Acknowledgement - that is, confirmation of request 1 working day from date of despatch of Notification of Access form by the Operator to the AP |
| | Minimum notice period: 3 working days from date of despatch of Notification of Access form by the Operator to the AP |

Table 5: Planned Access Lead-times

5.5.2 Unplanned Access

If the Operator requires access in less than the standard access lead-time, then the access request is said to be an unplanned access request.

The minimum lead times for unplanned access are specified in 5.3.

| | |
|------------------------|--|
| Standard Hours | Time of Access: within 3 hours of requested time of access stated on the Notification of Access form |
| Outside Standard Hours | Time of Access: within 4 hours of requested time of access on the Notification of Access form |

Table 6: Maximum Lead Times for Gaining Unplanned Access

5.5.3 Unescorted Access

If the Operator requires access Mon-Fri (excluding public hours) for Non Material Change work

| | |
|--|---|
| Unescorted Access Hours 0900 to 1800 (Mon-Fri, excluding public holidays) | Time of Access: within 2 hours of requested time of access on the Notification of Access form |
|--|---|

Table 7: Maximum Lead Times for Gaining Unescorted Access

5.6 On-Site Procedures

5.6.1 Identification

The Operator's staff and their contractors will be required to carry a photographic identification card provided by the AP (ENSUP Card) as proof of their identity and to display it at all times during the visit.

5.6.2 Responsibilities of the Operator

It is the responsibility of the Operator to ensure that:

- ▶ All staff or contractors have appropriate identity documents ENSUP card to allow them access to the colocation facility
- ▶ All staff and contractors must have site specific pack that includes drawings and site specific health and safety and method statements when carrying out material works.
- ▶ Staff requiring access are required to know the location of the Footprint and the Footprint ID, before they arrive at the colocation facility.

5.6.3 Escorts

Open air will provide an escort to supervise the access visit.

5.6.4 Working Practises

Whilst being subject to the appropriate Health & Safety legislation and emergency procedures, Operators' personnel are free to work hours as agreed with their employer. Open air will provide continuity of service.

Open air shall provide staff on a roster to provide continuous escort supervision, should this be required, under the existing planned and unplanned access arrangements.

5.6.5 Access Records

On completion of an access visit, the Open air escort will complete an Access Record form detailing:

- ▶ the site visited
- ▶ the time and duration of the access visit

The Access Request form will be used by Open air as the basis of the billing record for the access visit.

5.6.6 Access by Multiple Operators

In the event that multiple Operators require access at the same time, Open eir shall provide sufficient escorts to:

- ✔ Ensure safety within the colocation accommodation
- ✔ Escort Operator personnel to the accommodation from the building's entrance
- ✔ Escort Operator personnel to and from comfort breaks etc.

Actual costs will be recovered across all Operators present, pro-rata. Should both Operators be unable to work safely i.e. restricted space etc, then access will be allocated on first come first served basis.

6. Fault Repair

6.1 Scope

This sub-process covers the reporting of faults by Operators, reception and handling of these reports by Open eir and subsequent updating and clearance processes that should take place between the parties.

Faults within the Operator's network and operating domain are not the subject of this process. Operators are expected to have proven that fault lies with Open eir to a sufficient level of certainty before invoking this process.

6.2 Fault Reporting

There will be no pro-active fault reporting by Open eir, i.e. Open eir shall not inform Operators of faults in Open eir's exchange, unless any remedial works required to correct the fault fall within the scope of the emergency unplanned works outlined in Section 7.3.

Operators are responsible for reporting faults associated with colocation services to the Open eir NMC identified in Appendix H.

Faults shall be classed as service affecting or non-service affecting, by the Operator.

- ✔ Service affecting faults are those which directly affect the availability of customer connections, or which without remedy will substantially degrade the service to customers or remove its availability within a short period.
- ✔ Non-service affecting faults are those faults which without remedy could affect customer's or Operator operations in the longer term, whether directly or indirectly.

The Operator is requested to provide Open eir with as much guidance as possible to the potential cause of the problems, based on any alarm information it might have received.

Each fault shall be ascribed a unique fault report number and the Operator shall be informed of the latest response time for the diagnosis of the fault.

6.3 Statusing & Target Repair Times

Open eir shall provide the following status reports on the progress of faults. The Open eir NMC and fault maintenance staff are provided to facilitate 24/7 fault management processes.

| | Service Affecting Faults | Non-Service Affecting Faults |
|---------------------------|-----------------------------------|---|
| First response | one hour from time of reporting | one working day from date of reporting |
| Subsequent status reports | every hour thereafter | Every working day thereafter |
| Target repair times | four hours from time of reporting | three working days from date of reporting |

Table 8: Status Report Intervals & Target Repair Times

6.4 Escalation Procedures

The escalation of a problem may occur at two levels:

- If the target times for response specified in Table 8 have elapsed and the fault is not cleared, the appropriate Open eir Manager/Duty Manager shall be notified and appropriate action shall be taken to resolve the fault.
- In the event that the fault is still not cleared, and no evidence of progress exists, the second level of contact, the Management, shall be used to agree appropriate action to clear the fault.

| | Service Affecting Faults | Non-Service Affecting Faults |
|-------------------------|--|--|
| First level escalation | After target repair time (four hours from time of reporting) | after target repair time (three working days from date of reporting) |
| Second level escalation | after six hours from time of reporting | after four working days from date of reporting |

Table 9: Escalation Times

Contact details for the Manager / Duty Manager and Management are provided in Appendix H.

6.5 Clearance

Faults are only cleared when the problem has been fully remedied by Open eir. Should Open eir be unable to remedy a fault within the target time but is able to institute a work around, Open eir may consider a fault report closed for quality of service reporting purposes if:

- The Operator is informed that the fault clearance is conditional, eg a Work Around Pending Full Restoration code provided, and the Operator is informed of:
- the timing for the full restoration of service
- any associated planned or unplanned maintenance that may be required at that time

- any impact that such maintenance may have on the operation of the work around, and consequently the Operators equipment.

Clearance of the fault shall always be conditional on acceptance of the service as working by the Operator.

A number of valid fault clearance codes will be provided by Open eir in order to facilitate quality of service monitoring by the Operator, and can be found in Appendix C.

7. Planned and Unplanned Maintenance

7.1 Planned Works by Open eir

7.1.1 Introduction

This section describes procedures which are designed to minimise the effect of Planned Maintenance work on the Collocation product. Both Parties must observe safety precautions at all times. The procedures defined in the general Health and Safety requirements for Operators while on Open eir premises shall apply.

Notification to withdraw plant from service will be given to the Operator Network Management Centre (The Operator NMC).

In order to avoid problems it is essential that such work is planned and notified well in advance and is performed, under normal situations, within Preferred Hours as described in Section 7.1.2.

When it is not practicable and for certain categories of planned work e.g. for urgent investigations, relaxation of the Preferred Hours may apply. This shall be decided on a per case basis.

7.1.2 Preferred hours for major works

The standard periods allocated for Planned Maintenance work which requires system down time and where the Operators systems may be disrupted are shown below.

ALL DAYS 0100-0600

7.1.3 Notification Process and Timescale

If Open eir intends to carry out any planned work which may affect the Operators equipment then Open eir must notify the Operator of the planned work by email to the contact point as specified in Appendix H, using the "Request for Planned Works" form (see Appendix O).

The minimum advance notification that is required for service outages due to Planned Maintenance is 10 working days.

Having been notified of planned maintenance the Operator must review and respond to the proposal within 3 working days of receipt.

On completion of the Planned Maintenance work Open eir must notify the Operator that the work was completed as planned within 1 day the planned completion time, by e-mail of the completed "Notification for Planned Maintenance" form.

A reduction of notification time-scale will be allowed only under exceptional circumstances. Each occurrence will be treated as urgent planned work and the reason for the urgency should be stated.

7.1.4 Escalation

If the date or timing of the Planned Maintenance work is unsuitable then the Operator must contact the relevant inter-company escalation point so that a suitable date and time can be agreed. Escalation points for planned maintenance are shown in Appendix H of this document.

If the Planned Maintenance work is critical and essential to the operation of either party's network then one party cannot veto the other party's work.

7.2 Planned Works by the Operator

7.2.1 Access to Site

As detailed in Section 5.2.1

7.2.2 Scope of Works

Any works which fall within the scope of hazardous works identified in Appendix G require a permit from Open eir. Open eir shall also be responsible for gaining the permission of other co-located operators, should this be required.

7.3 Unplanned or Emergency Works by Open eir

Should any emergency or unplanned works undertaken by Open eir at the exchange either:

- fall within the scope of hazardous works identified in Appendix G
- or, take the form of anything that could be considered likely, by a reasonable person, to cause the interruption of the Operators service

Open eir shall inform the Operator through the channels outlined in Appendix H.

7.4 Unplanned Works by the Operator

7.4.1 Access to Site

As detailed in Section 5.2.2.

7.4.2 Scope of Works

Any works which fall within the scope of hazardous works identified in Appendix G require a permit from Open eir. Open eir shall also be responsible for gaining the permission of other co-located operators, should this be required.

7.5 Co-ordination of Hazardous Operations

Hazardous activities are addressed in the General Health and Safety Requirements for Operators while working on Open eir premises. All hazardous activities being undertaken by the Operator must be identified in either their generic Methods Statement (for Unforeseen Physical Change) or the specific Methods Statement prior to requesting access to conduct Physical Change.

Where co-ordination is required, this will be confirmed by Open eir based on the relevant Methods Statements from Operators. Appendix G details the scope of information required.

8. Billing

8.1 Introduction.

This process relates to the production and payment of bills associated with colocation services.

8.2 Billable Events

The following table provides a list of the valid billable events which form part of this process, as well as information on the audit trail that will be available to both parties from the processes defined in this document.

| Event | Audit Trail |
|--|--|
| Contract Completion | As per the Licence Agreement |
| Site Specific Information Request | Date of acknowledgement of SSIR form by the AP |
| Initial Survey Request | Date of acknowledgement of ISR form by the AP |
| Full Survey Request (small, medium or large) | Date of acknowledgement of FSR form by the AP |
| Site Offer | Date of acknowledgement of Site Offer request form by the AP |
| Combined Full Survey and Site Offer | Date of acknowledgement of CFSCSOR form by the AP |
| Site Preparation fee | As per Licence Agreement |
| Occupancy charge ("Licence Fee") | As per Licence Agreement |
| Power usage charge | Periodic charge. |
| Process charge | As per Access and Licence Agreements |
| Special Inspection | Date of receipt of request |
| Site Survey (QIB) | QIB order placed on UG |
| Accepted QIB Estimate | PIB order placed on UG |

Table 10: Billable Events

The licence fee ('occupancy charge') will be payable from the date when open eir approve the space request for an Operator.

For new sites the power usage charge will be payable from the date when the Operator starts their build work.

A minimum DC power usage of 0.4kW applies to all open eir DC power deployments for billing purposes.

8.3 Payment Terms

Invoices are due and payable in euros.

Invoices are payable as per the terms of the Access and Licence Agreements. Open eir shall provide with the invoice a breakdown of each charging category to validate the invoice.

All invoice queries shall be addressed to the LLU Billing Contact point listed in Appendix H.

8.4 Disputed Payments

Disputed payment claims must be submitted as per the Access and Licence Agreements.

9. Appendix A - Initial Survey Request Form

Initial Survey Request Form for Physical Collocation

Note: Failure to provide all requested information may result in delays in the processing of the Survey.

Order Details - sent by Operator X to Open eir.

| Open eir Contact Information | | Operator Contact Information | |
|------------------------------|--|------------------------------|--|
| Name* | | Name* | |
| Telephone No* | | Telephone No* | |
| Fax | | Fax | |
| E mail* | | E mail* | |
| Date:* | | Operator X Reference No.:* | |

For office use only
(Circle one of A/R only)
Then circle box →

Accept

Reject

Operator Information

| Operator Billing Address* : | Operator Contact Postal Address* : | A | R |
|--|------------------------------------|---|---|
| | | | |
| | | | |
| Carrier Services Billing Account Number* | | A | R |
| Operator' Order reference number* | | A | R |
| Anticipated due date* | | A | R |

Exchange Information

| | | | |
|------------------------|--|---|---|
| Exchange Name* | | A | R |
| Short code identifier* | | A | R |
| Address / grid ref.* | | A | R |

MDF Block Information (CoLo for LLU)*

| | | | |
|--------------------------------------|--|---|---|
| Number of MDF terminations required: | | A | R |
|--------------------------------------|--|---|---|

Footprint Information*

| Number of footprints : | | No. | A | R |
|----------------------------|--------------|-----|---|---|
| Footprint layout required: | Side-by-Side | | A | R |
| | Back-to-Back | | A | R |

Power requirements should be inserted into this form

Heat dissipation should be inserted into this form

Order details (to be completed by Open eir)

| | | |
|-------------------|--|--|
| Date received | | |
| Date Acknowledged | | |

* indicates mandatory field

Appendix B - Survey & Offer Request Form

Full Survey Request Form for Physical Collocation Service

Note: Failure to provide all requested information may result in delays in the processing of the Survey/Offer.

Full Survey
 Site Offer
 Combined Full Survey and Site Offer

Order Details - sent by Operator X to Open eir.

| Open eir Contact Information | | Operator Contact Information | |
|------------------------------|--|------------------------------|--|
| Name* | | Name* | |
| Telephone No* | | Telephone No* | |
| Fax | | Fax | |
| E mail* | | E mail* | |
| Date:* | | Operator X Reference No.: | |

For office use only
(Circle one of A/R only)
Then circle box →

Accept

Reject

Operator Information

| Operator Billing Address* : | Operator Contact Postal Address* : | A | R |
|--|------------------------------------|---|---|
| | | | |
| | | | |
| Carrier Services Billing Account Number* | | A | R |
| Operator's order ref. number* | | A | R |
| Anticipated due date* | | A | R |

Exchange Information

| Exchange Name* | | A | R |
|------------------------|--|---|---|
| Short code identifier* | | A | R |
| Address / grid ref.* | | A | R |

Dedicated phone line requirement*

| Is a phone required? | Yes / No | A | R |
|----------------------|----------|---|---|
| | | | |

MDF Block Information (CoLo for LLU)*

| Number of MDF terminations required: | | A | R |
|--------------------------------------|--|---|---|
| | | | |

Footprint Information*

| Number of footprints : (footprint 600x400) | | No. | | |
|--|--|-----|---|---|
| Footprint layout required: (Indicate order of preference) | | | A | R |
| Contiguous footprints with rear access Note: space reserved for rear access will be chargeable as footprint space | | | | |

| | | | | |
|--|--|-----|---|---|
| Contiguous footprints without rear access | | | | |
| Non contiguous footprints with rear access Note: space reserved for rear access will be chargeable as footprint space | | | | |
| Non contiguous footprints without rear access | | | A | R |
| | | Y/N | A | R |
| | | Y/N | A | R |
| | | | A | R |
| Equipment weight (N/m ²) | | | A | R |
| Footprint 1 (N/m ²) | | | | |
| Footprint 2 (N/m ²) | | | | |
| Footprint 3 (N/m ²) | | | | |
| Footprint 4 (N/m ²) | | | | |
| | | | | |
| TOTAL (N/m ²) | | | A | R |
| Heat Dissipation | | | A | R |
| Footprint 1 | | | | |
| Footprint 2 | | | | |
| Footprint 3 | | | | |
| Footprint 4 | | | | |
| | | | | |
| TOTAL | | | A | R |

DC Power Information (If AC power please specify)**

| | | | | |
|-----------------------|--|--|---|---|
| DC Power Drain (Amps) | | | A | R |
| Footprint 1 | | | | |
| Footprint 2 | | | | |
| Footprint 3 | | | | |
| Footprint 4 | | | | |
| | | | | |
| TOTAL | | | A | R |

DC Distribution Information 2 breakers provided per footprint (see above)*

| MCB Rating (amps) | Type (A,B or C) | Quantity required | Planned CSA of distribution cable (mm ²) ¹ | | |
|-------------------|-----------------|-------------------|---|---|---|
| 10 | | | | A | R |
| 16 | | | | A | R |
| 20 | | | | A | R |
| 25 | | | | A | R |
| 32 | | | | A | R |
| 40 | | | | A | R |
| 63 | | | | A | R |

¹ AP may require the Operator to install DC distribution cable more suitable to DC conditions on site (see above). Tie Cable Provided by Operator*

| Tie Cable | Size (cable diameter) | Number | A | R |
|-----------|-----------------------|--------|---|---|
| | | | | |
| | | | | |



| | | | | |
|--|--|--|--|--|
| | | | | |
| | | | | |

Order details *(to be completed by Open eir)*

| | | |
|-------------------|--|--|
| Date received | | |
| Date Acknowledged | | |

** indicates mandatory field*

Appendix C - Valid Fault Clearance Codes

Valid Fault Clearance Codes

- Right When Tested
- Fault Not Found
- Power
- Air conditioning
- Other environmental
- Fault proved back to operator's network
- Work Around Pending Full Restoration
- Emergency (fire, flood, explosion, acts of god)
- Other.

Appendix D - Access Record Form

| | | | |
|--|----------------|--|------------------|
| | Planned Access | | Unplanned Access |
|--|----------------|--|------------------|

| | |
|-------------------------|--|
| Operator Organisation | |
| Exchange Name | |
| Short Code Identifier | |
| Visit Reference Number | |
| Date of Visit | |
| Booked entry time | |
| Booked exit time | |
| Actual Time In | |
| Actual Time Out | |
| Escort Name | |
| Operator Representative | |
| Organisation | |

| | |
|-----------------------|-----------------------|
| Signed by | Signed by |
| | |
| On behalf of Open eir | On behalf of Operator |
| Date | Date |



Appendix E - Equipment Notification Form

Equipment Notification Form

| | | |
|------------------------------|----------------|------------------|
| Operator | | |
| Date of Registration | | |
| | | |
| Manufacturer | | |
| Model Name / Number | | |
| | | |
| Standards Information | | |
| | Standards Body | Reference Number |
| Health and Safety | | |
| Electromagnetic emissions | | |
| Electrical power interface | | |

| | | | |
|--|-----|--|----|
| Certification that product complies with the relevant Spectrum Mask standards | | | |
| Does the equipment conform to the Copper Loop Frequency Management Plan? | Yes | | No |
| Initials of signatory | | | |
| | | | |

| |
|--------------------|
| Signed by |
| |
| On behalf of |
| Date |

Open eir use

| | |
|-------------------------|--|
| Date Received | |
| Date Placed in Register | |
| | |



Appendix F - Site Specific Information Request Form

Site Specific Information Request Form

| |
|--|
| Site Specific Information Request Form for Physical Collocation Service |
| Note: Failure to provide all requested information may result in delays in the processing of the Request. |

Order Details - sent by Operator X to Open eir.

| Open eir Contact Information | | Operator Contact Information | |
|------------------------------|--|------------------------------|--|
| Name* | | Name* | |
| Telephone No* | | Telephone No* | |
| Fax | | Fax | |
| E mail* | | E mail* | |
| Date:* | | Operator X Reference No.:* | |

For office use only
(Circle one of A/R only)
Then circle box →

| |
|--------|
| Accept |
| Reject |

Operator Information

| | | | |
|--|------------------------------------|---|---|
| Operator Billing Address* : | Operator Contact Postal Address* : | A | R |
| | | | |
| | | | |
| Carrier Services Billing Account Number* | | A | R |
| Order reference number* | | A | R |
| Anticipated due date* | | A | R |

Exchange Information

| | | | |
|------------------------|--|---|---|
| Exchange Name* | | A | R |
| Short code identifier* | | A | R |
| Address / grid ref.* | | A | R |

Order details (to be completed by Open eir)

| | | |
|-------------------|--|--|
| Date received | | |
| Date Acknowledged | | |

** indicates mandatory field*



Appendix G - Hazardous Operations

Hazardous Operations

As per Open eir's Access Reference Offer, Annex 3, Service Schedule 101 - Appendix 3.



Appendix H - Contact and Escalation Points

Contact and Escalation Points

To be completed by the parties at the time of Licence signature.

Appendix I - Notification of Access Form

Notification of Access Form

| | | |
|---|----------------|------------------|
| Access Request for Physical Colocation Planned and Unplanned access: e-mail to carrierservices@openeir.ie | | |
| Note: Failure to provide all requested information may result in delays in the processing of the access request. | | |
| | | |
| Extension Planned Access | Planned Access | Unplanned Access |

Exchange Information

| | | | |
|------------------------|--|---|---|
| Exchange Name* | | A | R |
| Short code identifier* | | A | R |
| Address / grid ref.* | | A | R |

Visit Information

| | | | |
|---------------------------|---------|----------------|---------------------|
| Date access required* | | A | R |
| Time* | | A | R |
| From | To | | |
| Booked length* | | | |
| Number of staff visiting* | | A | R |
| Name | Company | Contact number | Registration number |
| | | | |
| | | | |
| | | | |
| | | | |
| | | | |
| | | | |
| | | | |
| | | | |
| | | | |
| | | | |
| | | | |

| | | | |
|--|-----|--|----|
| Proposed work to be undertaken*: | | | |
| Does this work constitute Physical Change? | Yes | | No |
| Has an approved Methods Statement been submitted for this work? * (if no, then access will not be granted) | Yes | | No |
| Reference number of the Method Statement covering this work | | | |

Order Details - sent by Operator X to Open eir.

| | | | |
|------------------------------|--|------------------------------|--|
| Open eir Contact Information | | Operator Contact Information | |
| Name* | | Name* | |
| Telephone No* | | Telephone No* | |

| | | | |
|---------|----------------------------|---------|--|
| Fax | | Fax | |
| E mail* | | E mail* | |
| Date:* | Operator X Reference No.:* | | |

Operator Information

| | | | |
|--|--|---|---|
| Operator Billing Address* : | | A | R |
| | | | |
| | | | |
| | | | |
| Carrier Services Billing Account Number* | | A | R |
| Order reference number* | | A | R |

Order details *(to be completed by Open eir)*

| | | |
|------------------------|--|--|
| Date received | | |
| Date Acknowledged | | |
| Visit Reference Number | | |

* indicates mandatory field

Appendix J - Site Preparation Works Certificate

| | |
|-------------------------|--|
| Exchange Name | |
| Short Code Identifier | |
| | |
| Completion Date | |
| Footprint location | |
| | |
| Operator Name | |
| | |
| Operator Representative | |
| Open eir Representative | |

Service Order Preparation Verification

| Action Required | Access Provider | | | | Operator |
|---|-----------------|--|----|--|----------|
| CoLo for LLU or VUA or Interconnect or CEI ? | | | | | |
| DC or AC power ? | | | | | |
| Service Order Ref Number | | | | | |
| Operator fibre sub-duct installed to Exchange chamber | | | | | |
| Provisioning of Exchange Opes | | | | | |
| Was a Phone requested. <i>If yes has this been installed</i> | Yes | | No | | |
| Footprint Requested. <i>Enter number of each requested</i> | Side by Side | | | | |
| | Back-to-Back | | | | |
| Was rear access to footprints requested? <i>If yes has this been installed?</i> | Yes | | No | | |
| Were additional requirements for footprints requested? <i>If yes have these been installed?</i> | Yes | | No | | |
| Number of MDF terminations requested | | | | | |
| Earth Window Connected | | | | | |
| DC Power Information <i>Indicate DC voltage connected</i> | | | | | |
| FP 1 | | | | | |
| FP 2 | | | | | |
| FP 3 | | | | | |
| FP 4 | | | | | |
| | | | | | |
| | | | | | |



DC Distribution Information

| MCB Rating (amps) | Type (A,B or C) | Quantity requested | CSA of distribution cable (mm ²) | AS | AP |
|-------------------|-----------------|--------------------|--|----|----|
| 10 | | | | | |
| 16 | | | | | |
| 20 | | | | | |
| 25 | | | | | |
| 32 | | | | | |
| 40 | | | | | |
| 63 | | | | | |

Tie Cable Provided

| Tie Cable | Size (cable diameter) | Number | AP | AS |
|-----------|-----------------------|--------|----|----|
| | | | | |
| | | | | |
| | | | | |
| | | | | |

Comments:

| | |
|-----------------|--|
| Access Provider | |
| Operator | |

| | |
|-----------------------|-----------------------|
| Signed by | Signed by |
| | |
| On behalf of Open eir | On behalf of Operator |
| Date | Date |



Appendix K - Workflows (For illustrative purposes only)

Site Specific Information Report

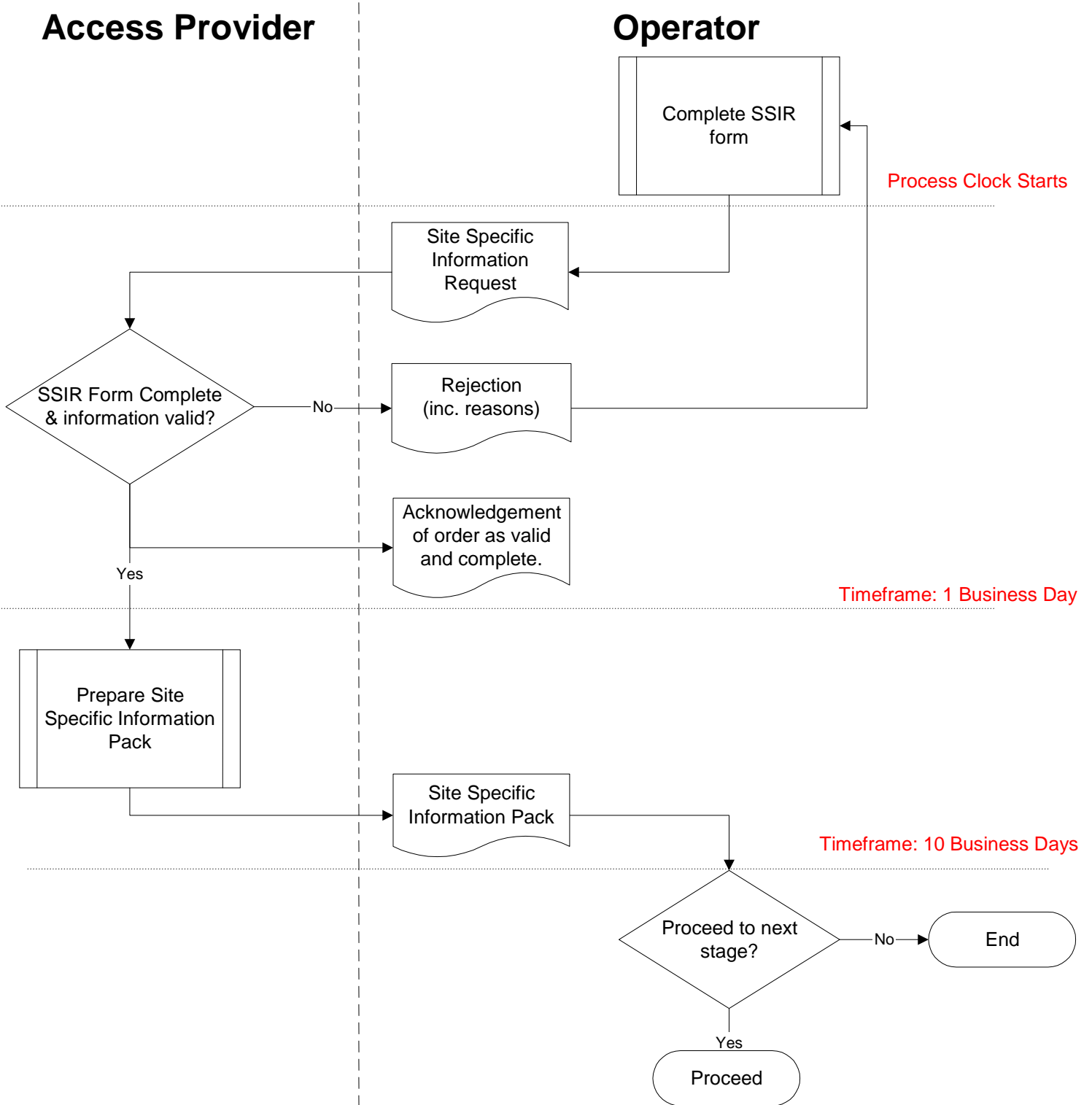



Initial Survey Request

Access Provider

Operator

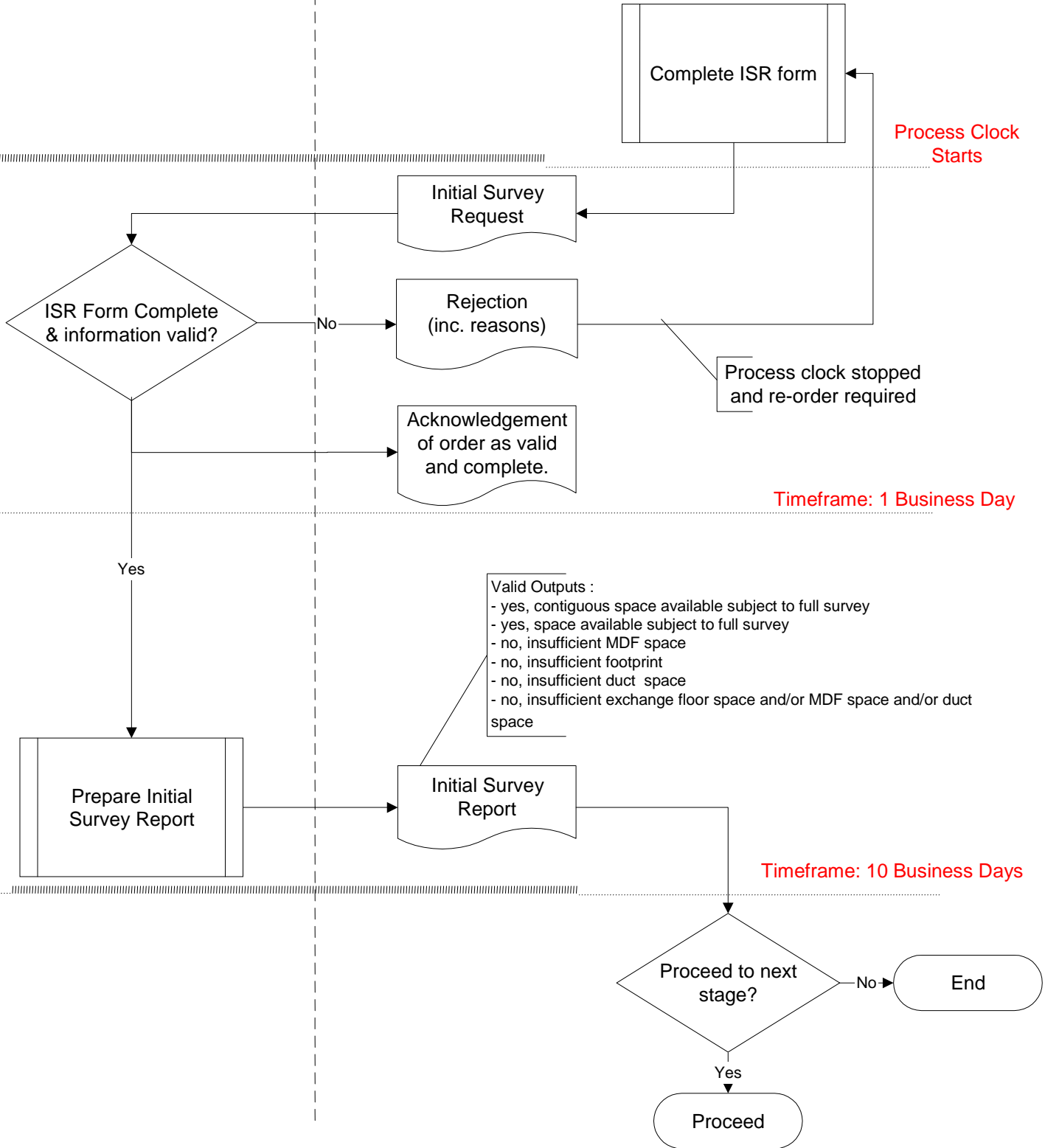

Full Survey Request

Access Provider

Operator

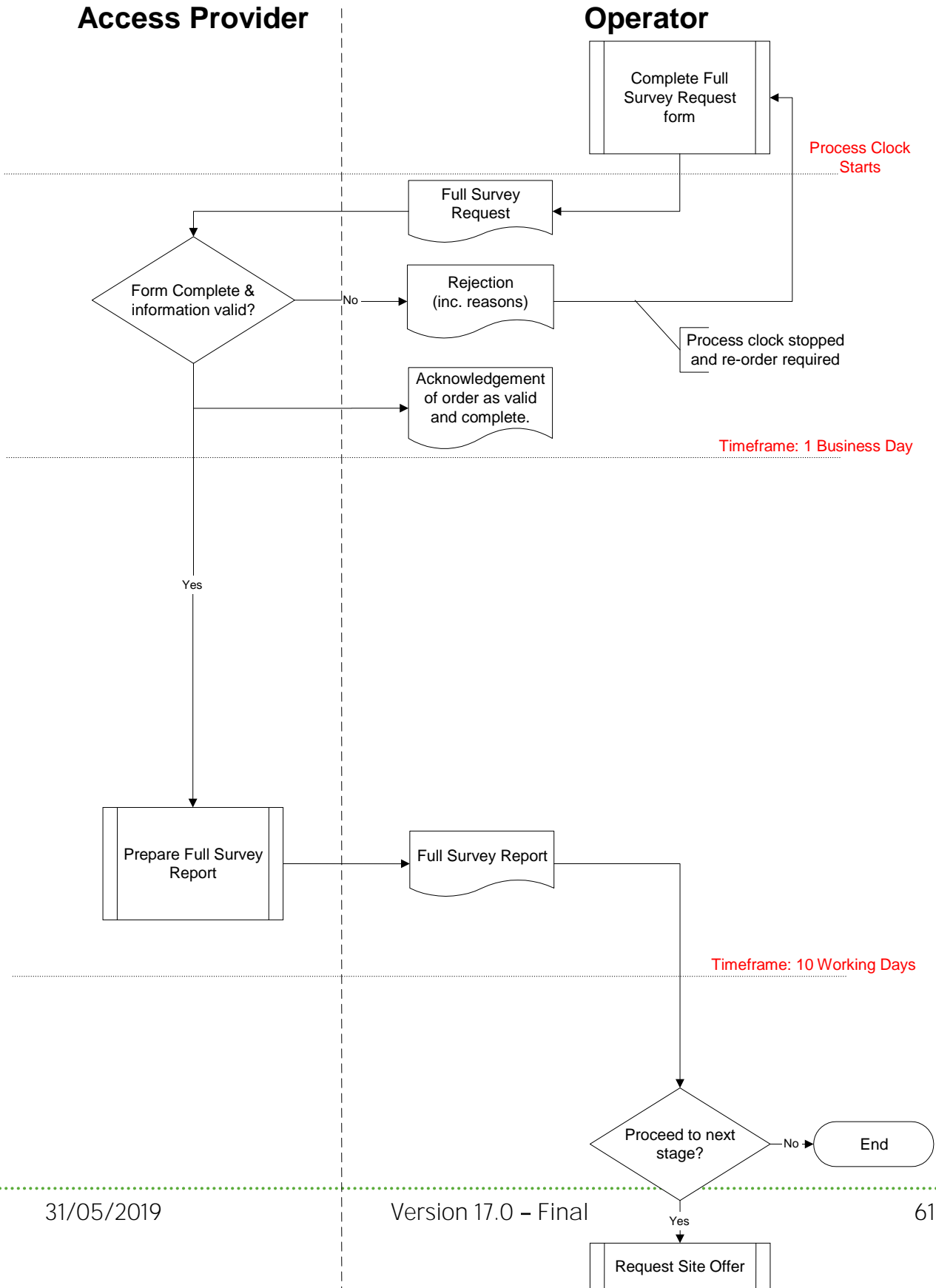

Site Offer Request

Access Provider

Operator

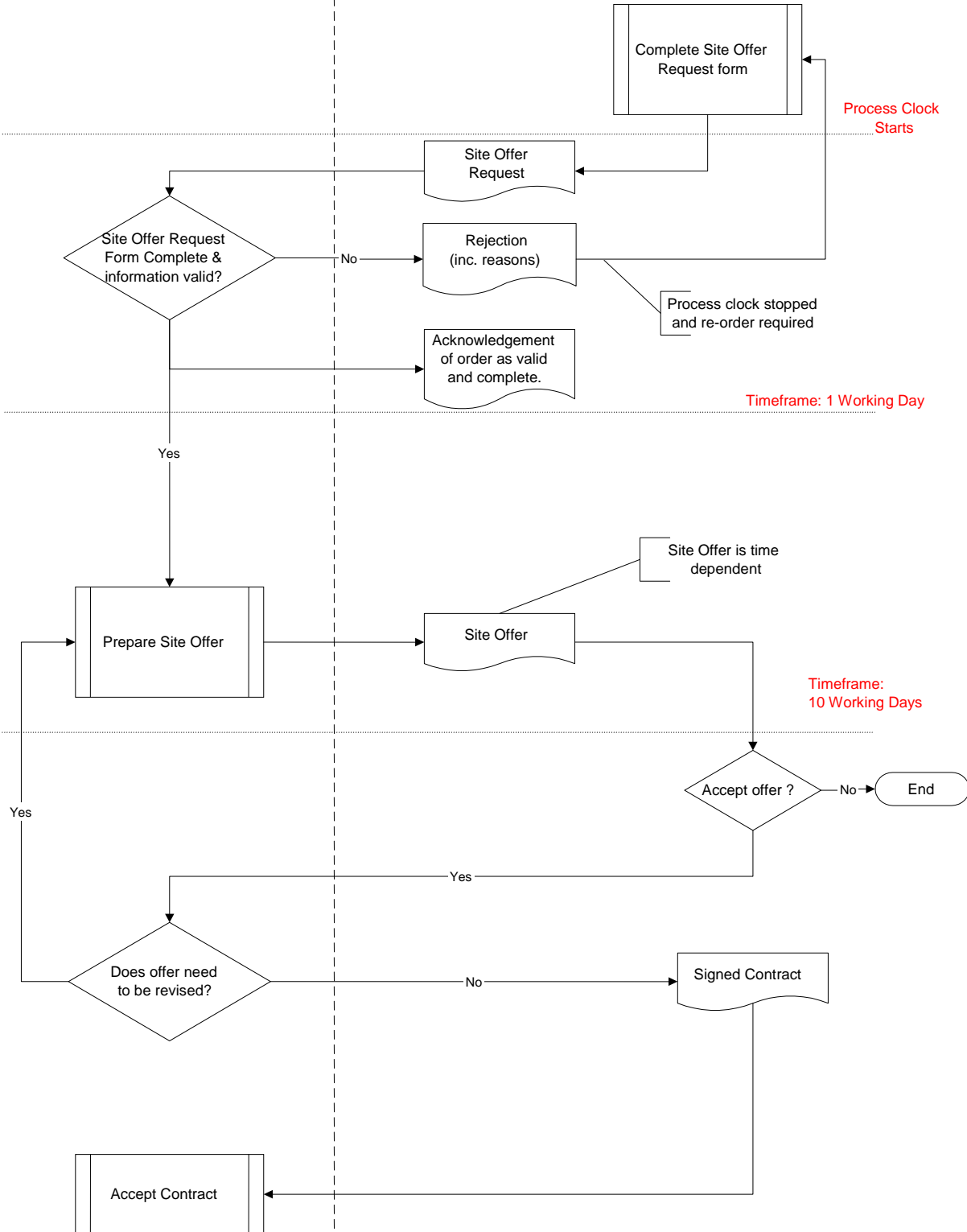

Combined Full Survey and Site Offer Request

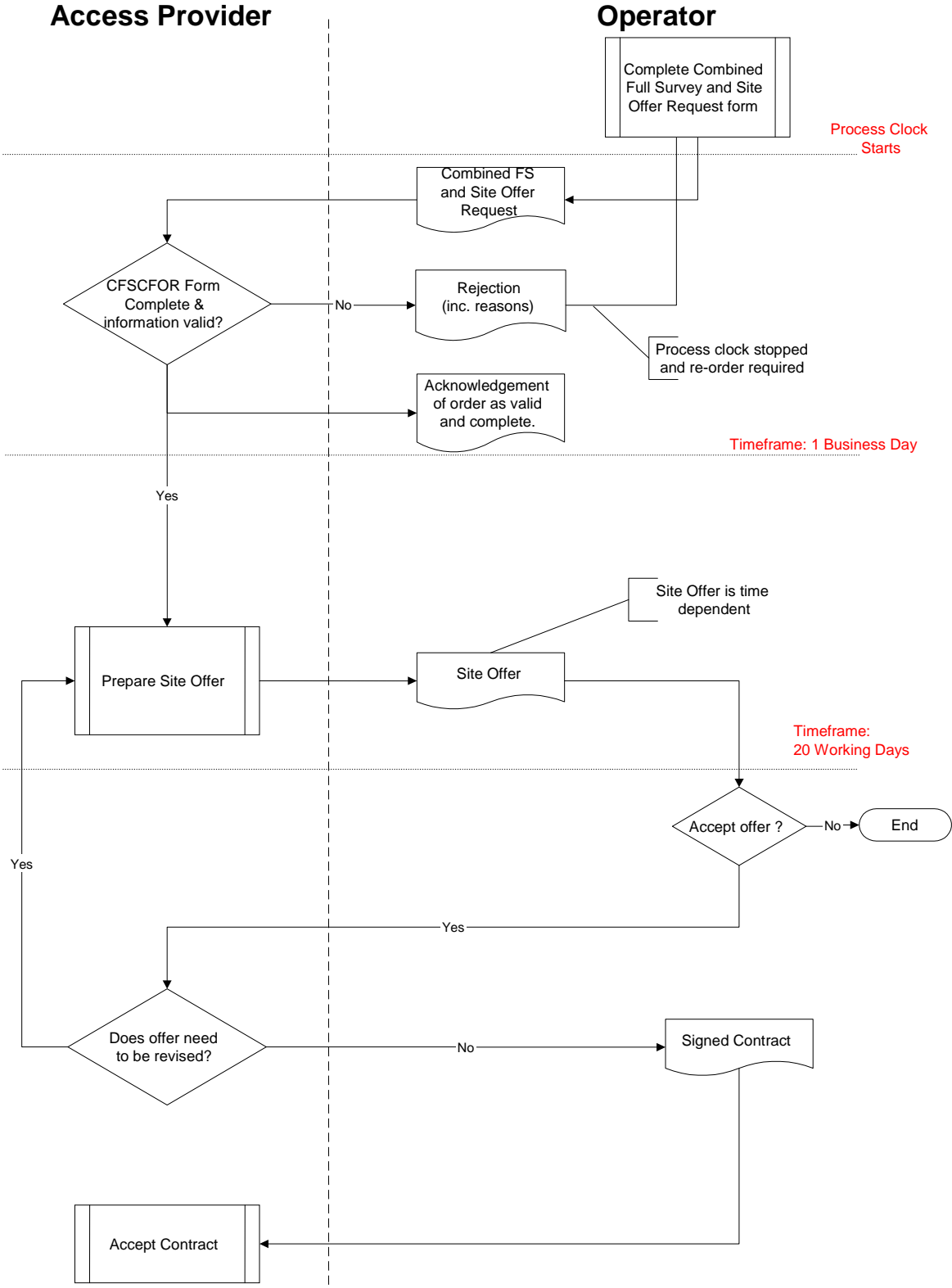

Operator / Contractor Registration and Accredited process

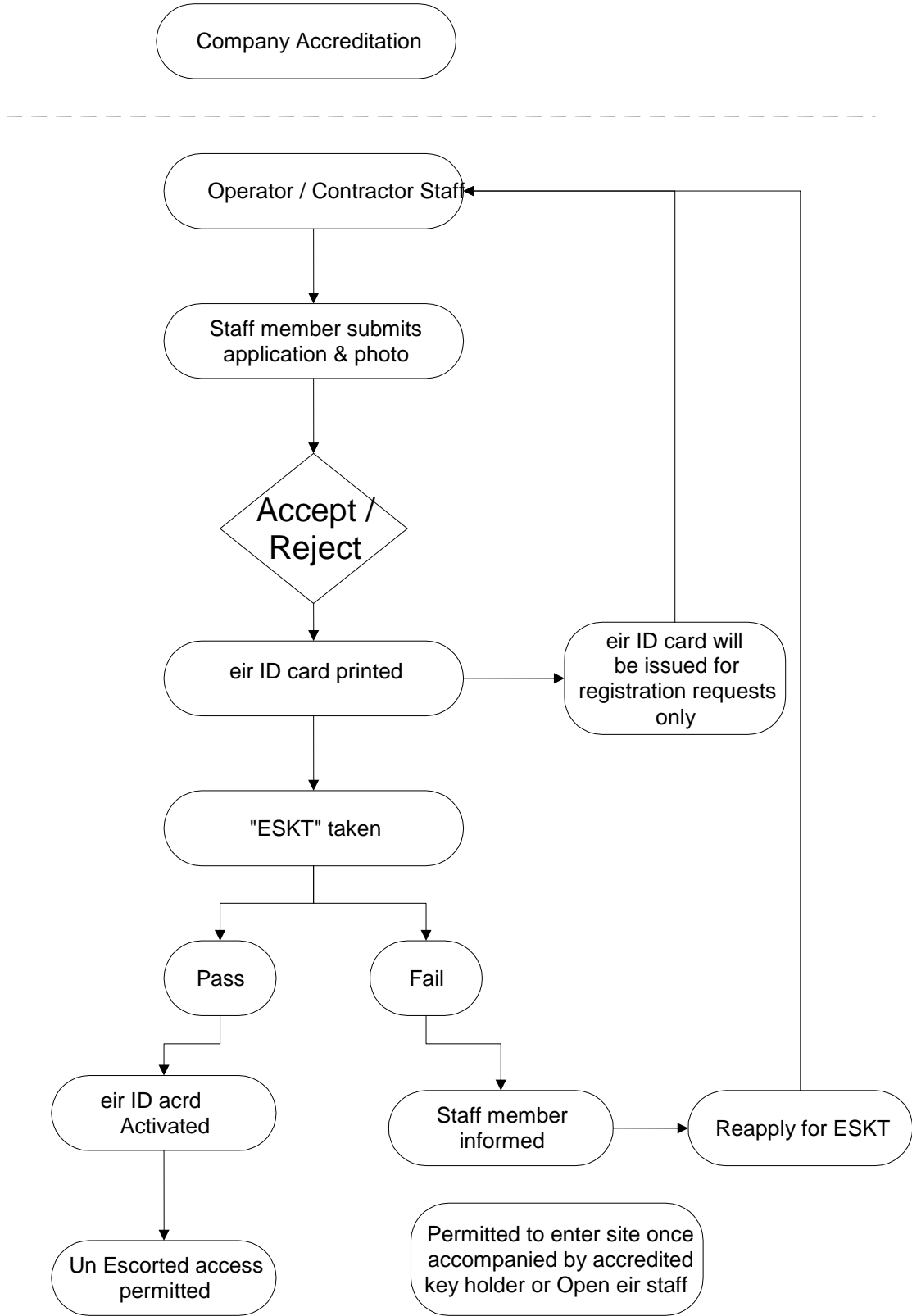



APPENDIX L - CO-LOCATION EQUIPMENT REGISTER

CO-LOCATION EQUIPMENT REGISTER

| CO-LOCATION EQUIPMENT REGISTER | | | |
|--------------------------------|------------|--------------|-----------------|
| EFFECTIVE FROM: 01 NOV 01 | | | |
| MANUFACTURER | MODEL NAME | MODEL NUMBER | DATE REGISTERED |
| | | | |
| | | | |

APPENDIX M – ID APPLICATION FORMS

Application for Operator ID Part 1

This form is to be completed only by an accredited Operator requiring access to eir network buildings. Complete the Sections 1 to 6 below and submit to the relevant Open eir Co-location manager.

1. Accredited Operator Company

| | |
|--|--|
| Accredited Company Name | |
| Name of Company's Representative to Open eir | |
| Accreditation Reference Number | |

2. Individual Details

| | |
|--|---|
| Name (block letters) | |
| Signature | |
| Relation to Accredited Company <i>(Tick One Only)</i> | <input type="checkbox"/> Employed by <input type="checkbox"/> On Contract to |
| Office Telephone No. | |
| Mobile Telephone No. | |
| Email (if applicable) | |
| Safe Pass Registration No. ⁸ | |
| Safe Pass Expiry Date (dd/mm/yyyy) | |

3 Photograph of Applicant:

All Application Forms must be accompanied by a passport sized photograph which must be signed on the reverse side by the applicant. An attached digital photograph is acceptable.

Attached signed
Photograph here

⁸ Current Safe Pass is a requirement for working in network buildings.



4. Qualifications and Experience

Please list relevant professional/technical qualifications.

Open eir in-house training courses.

| Qualifications |
|----------------|
| |

Please give details of relevant work experience⁹:

| Experience |
|------------|
| |

5. Applicant Declaration

The applicant must sign the following declaration:

I hereby declare that I have been briefed on eir’s general Health and Safety Requirements for Access Seekers and Risk & Security Management Procedures. I understand and accept my legal obligations and responsibility under each of the above documents.

Signature of Applicant: _____
 Name of Applicant: _____
 (BLOCK CAPITALS)
 Date: _____

6. Declaration by Operator Representative

Tick one of the 2 applicable options only

I confirm that the applicant was briefed on the aforesaid documents on _____ (Date) by _____

Another company _____ has briefed this applicant previously.
(Provide Company Name)

The representative of the Operator to Open eir must sign each application:

Signature of Operator representative _____
 Date: _____

Return this form to the relevant Open eir Co-location manager

⁹ In order to qualify for accreditation, candidates must have worked in the telecommunications industry for a minimum of 3 years or have an appropriate level of relevant experience.

Note:

1. *The cardholder is responsible for the security of their ID card. If the card is lost or stolen, the incident must be reported immediately to eir Facilities Helpdesk 1800 701434.*
2. *The information entered on this form will be used by eir for*
 - (a) *Processing your application*
 - (b) *Contact details regarding Open eir business.*
3. *The eir ID/Access card can be used only by the person to whom it is issued*
4. *eir maintain an access control database that may be used to track individuals whereabouts on company premises. This information is used to investigate security incidents or failure to comply with security procedures only.*
5. *eir may cancel accreditation at any time.*
6. *Access by any individual to any eir site will be refused where a completed ID application form has not been submitted and approved by eir.*
7. *All accredited persons must display the eir ID while working on Open eir premises.*
8. *eir uses closed circuit TV in certain of its secure facilities. While eir will endeavour, by way of signage, to notify persons on the facility of the use of CCTV, the cardholder acknowledges that CCTV is used by eir in certain secure environments. This information is used to investigate security incidents or failure to comply with security procedures only*
9. *The ID card must be surrendered to eir, if the cardholder has left the employment of the OAO. eir must be informed immediately of this event.*



Appendix N - Installed Equipment Safety Certificate

Installed Equipment Safety Certificate

| | |
|-------------------------|--|
| Exchange Name | |
| Short Code Identifier | |
| | |
| Footprint location | |
| | |
| Operator Name | |
| | |
| Operator Representative | |
| Open eir Representative | |

| | |
|-----------------------|-----------------------|
| Signed by | Signed by |
| | |
| On behalf of Open eir | On behalf of Operator |
| Date | Date |



APPENDIX O - REQUEST FOR PLANNED WORKS

REQUEST FOR PLANNED WORKS

| | |
|--|--|
| To: <i>(Operator NMC)</i> | Reference Number: <i>(AP's internal reference)</i> |
| From: <i>(AP NMC)</i> | Date: |
| Address: <i>(AP NMC address)</i> | |
| Telephone No: <i>(AP contact telephone number)</i> | |
| Fax No: <i>(AP contact fax number)</i> | |
| Email: <i>(AP contact email address)</i> | |

Engineering work is due to be carried out and will necessitate the following break in service to:-

(description of potential network outages)

Break Description:
Start Date/time of Break:
Finish Date/time of Break:
Comments: *(eg reason for planned works)*

| | | |
|---|--------|---|
| Originator's Initial: | Issue: | 1 |
| Received by: | Date: | |
| Agreed/Disagreed by: | Date: | |
| Amendment Received by: | Date: | |
| Amendment Agreed by: | Date: | |
| Engineering work completed as planned: | | |
| Signed: | Date: | |



Appendix P - Expansion of Capacity Form

Expansion of Capacity Form

Note: Failure to provide all requested information may result in delays in the processing of the Survey/Offer. Please fully complete the relevant section based on your requirements.

This form can only be used when the requesting Operator has an existing installation in the requested exchange location

Incremental Build Request ¹ Expansion of Capacity Request

Additional MDF Space Additional Power Provision of Additional Tie Cable

Order Details - sent by Operator X to Open eir.

| Open eir Contact Information | | Operator Contact Information | |
|------------------------------|--|------------------------------|--|
| Name* | | Name* | |
| Telephone No* | | Telephone No* | |
| Fax | | Fax | |
| E mail* | | E mail* | |
| Date:* | | Operator X Reference No.:* | |

For office use only
(Circle one of A/R only)

Accept
Reject

Operator Information

| | | | |
|--|------------------------------------|---|---|
| Operator Billing Address* : | Operator Contact Postal Address* : | A | R |
| Carrier Services Billing Account Number* | | A | R |
| Operator's order ref. number* | | A | R |
| Anticipated due date* | | A | R |
| FSR issue date | | A | R |

Exchange Information

| | | | |
|------------------------|--|---|---|
| Exchange Name* | | A | R |
| Short code identifier* | | A | R |
| Address / grid ref.* | | A | R |

Additional MDF Block Information

| | | | |
|---|--|---|---|
| Number of Additional MDF terminations required: | | A | R |
|---|--|---|---|

Additional Footprint Information

| | | | | |
|---|--|-----|---|---|
| Existing Footprint Codes/Location Note: If applicable please include site drawings | | | | |
| Number of additional footprints : | | No. | | |
| Footprint layout required: | Side-by-Side | | A | R |
| | Back-to-Back | | A | R |
| Contiguous footprint required? | | Y/N | A | R |
| Rear access to footprint required? | Note: space reserved for rear access will be chargeable as footprint space | Y/N | A | R |
| Order of preference for footprint layout. | | | | |
| Additional requirements for footprint layout, if applicable | | | A | R |
| Equipment weight (N/m ²) | | | A | R |
| Footprint 1 (N/m ²) | | | | |
| Footprint 2 (N/m ²) | | | | |
| Footprint 3 (N/m ²) | | | | |
| | | | | |
| TOTAL (N/m ²) | | | A | R |
| Heat Dissipation | | | A | R |
| Footprint 1 | | | | |
| Footprint 2 | | | | |
| Footprint 3 | | | | |
| | | | | |
| TOTAL | | | A | R |

Additional DC Power Information

| | | | | |
|-----------------------|--|--|---|---|
| DC Power Drain (Amps) | | | A | R |
| New Footprint 1 | | | | |
| New Footprint 2 | | | | |
| New Footprint 3 | | | | |
| | | | | |
| TOTAL | | | A | R |

Additional DC Distribution Information

| MCB Rating (amps) | Type (A,B or C) | Quantity required | Planned CSA of distribution cable (mm ²) ¹ | | |
|-------------------|-----------------|-------------------|---|---|---|
| 10 | | | | A | R |
| 16 | | | | A | R |
| 20 | | | | A | R |
| 25 | | | | A | R |
| 32 | | | | A | R |
| 40 | | | | A | R |
| 63 | | | | A | R |

¹ AP may require the Operator to install DC distribution cable more suitable to DC conditions on site
Cable Provided by Operator*

| Tie Cable | Size (cable diameter) | Number | A | R |
|-----------|-----------------------|--------|---|---|
| | | | | |
| | | | | |
| | | | | |

Order details (to be completed by Open eir)



| | | |
|-------------------|--|--|
| Date received | | |
| Date Acknowledged | | |

** indicates mandatory field*

 Appendix Q - Notification of Access Form

Notification of Access Form: unescorted Access

Access Request for Physical Collocation
Unescorted Access: e-mail to carrierservices@openair.ie
Subject Title: Unescorted Access _+ Operator Name

Note: Failure to provide all requested information may result in delays in the processing of the access request.

Exchange Information

| | |
|------------------------|--|
| Exchange Name* | |
| Short code identifier* | |
| Address / grid ref.* | |

Visit Information

| | | | | |
|---------------------------|----------|-----------------|--------------|--|
| Date access required* | | | | |
| Time* | | | | |
| From | | To | | |
| Booked length* | | | | |
| Number of staff visiting* | | | | |
| Name* | Company* | Contact number* | Card Number* | |
| | | | | |
| | | | | |
| | | | | |

Proposed work to be undertaken *:

| | | | | |
|--|-----|--|----|--|
| | | | | |
| Does this work constitute Physical Change? | Yes | | No | |
| Has an approved Methods Statement been submitted for this work? * (if no, then access will not be granted) | Yes | | No | |
| Reference number of the Method Statement covering this work | | | | |

Appendix R – Access Rights

Application Form for Change of Access Rights for Operators to Access Buildings

This form is used to apply for a change of access rights to Open eir network buildings. The Operator Company must be accredited and the applicant must hold a valid ID card.

This form is not to be used to apply for a new ID card.

Section 1.0. Personal Details

| | | |
|---|------------|---------|
| Name | First Name | Surname |
| Operator Company Name <i>(Name of accredited Operator)</i> | | |
| Work Address: | Section | |
| | Building | |
| | Street | |
| | Town | |
| | County | |
| Access Card Reference No. | | |
| Contact Telephone No. | | |
| Safe Pass Registration No. ¹⁰ | | |
| Safe Pass Expiry Date (dd/mm/yyyy) | | |

Section 2.0. Details of Access Required:

| | | |
|--|--|--|
| 2(a) Type of Access Required <i>(Tick One of the Access Options Only)</i> | Unescorted <input type="checkbox"/> | Escorted <input type="checkbox"/> <i>(Assign Access On Demand)</i> |
| 2(b) Access Level Required <i>(Unescorted Access Only)</i> | | |
| <i>Complete 2 (c) to (e) where access to specified buildings and areas is needed</i> | | |
| 2(c) Exchange Areas into which Access is Required <i>(tick both boxes if necessary)</i> | Site Only Unrestricted Areas <i>(MDF/Welfare)</i> Restricted Areas <i>(Apparatus Power/Battery Rooms).</i> | <input type="checkbox"/> <input type="checkbox"/> <input type="checkbox"/> |
| 2(d) Specify Building Name(s) if required by access detailed above. <i>(List Names on separate sheet if more than 5 required)</i> | | |
| 2 (e) Specify Time of Access | Not Required | |

Section 3.0 Qualifications and Experience

¹⁰ Current Safe Pass is a requirement for working in network buildings.

Fill in this section if the applicant requires unescorted access with permanent access rights for unsupervised non-material change work. Please list relevant professional/technical qualifications.

| Qualifications |
|----------------|
| |

Please give details of relevant work experience¹¹:

| Experience |
|------------|
| |

Section 4.0. Applicant Declaration

4(a) Applicant Confirmation

I agree to comply with the conditions of acceptance detailed at the end of this form.

Name of Applicant:

4(b) Operator Company Representative

This applicant is employed by, or sub contracted to, the Operator Company detailed in section 1, and requires the access detailed in section 2 in order to satisfactorily carry out his work.

Name of Operator Company representative

Date (dd/mm/yy)

(Send Application form to the relevant Open eir Co-Location Manager)

Section 5.0 Authorisation by Co-Location Manager

The Co-location Manager for the relevant Operator must authorise each application.

Name of Open eir Co-Location Manager relevant to Operator:

Date

¹¹ In order to qualify for accreditation, candidates must have worked in the telecommunications industry for a minimum of 3 years or have an appropriate level of relevant experience.

Section 6.0 Operator Test

If the applicant requires unescorted access with permanent access rights for unsupervised non-material change work, the Co-location Manager shall arrange for applicant to be tested.

The applicant must have a current Safe Pass card in order to qualify for permanent access rights. Based on their qualifications and experience (See Section 3) applicants will be interviewed on

- The Open eir Safe Exchange Programme
- Knowledge of the location of Operator relevant equipment.
- Compliance on building entry procedures.
- Responsible actions while on Open eir company premises.

Date of Test (dd/mm/yyyy)

Result of Test
 Pass
 Fail
 Exempt

Name of Examiner
 Job Title of Examiner

(Send Form to Core Network Operations Administration Office)

Section 7.0 Core Network Operations

Access as detailed in section 2 is approved
 Access is Rejected

Give reason (if access rights have been rejected/modified from that detailed in section 2)

Core Network Facilities Manager

Date: dd/mm/yy

(Approved Applicants only are sent to the Access Administration office. Return rejected applications to the Co-Location Manager)

Completed forms are sent to

Open eir Access Administrator
 Room 002,
 Knockmay
 Portlaoise
 Co. Laois
 Telephone: 0502-82851

Alternatively e-mail completed and authorised form to Access Administration.

For use by administrator only

| | |
|--------------------------------|------------|
| Date of receipt of application | (dd/mm/yy) |
| Date of Implementation | (dd/mm/yy) |

Section 8.0 Conditions of Acceptance



-
- a) *The cardholder is responsible for the security of their ID card. If the card is lost or stolen, the incident must be reported immediately to Open eir Facilities Helpdesk 1800 701434.*
 - b) *The information entered on this form will be used by Open eir for*
 - c) *Processing your application*
 - d) *Contact details regarding Open eir business.*
 - e) *The Open eir ID/Access card can be used only by the person to whom it is issued*
 - f) *Open eir maintain an access control database that may be used to track individuals whereabouts on company premises. This information is used to investigate security incidents or failure to comply with security procedures only.*
 - g) *Open eir may can cancel accreditation at any time.*
 - h) *Access by any individual to any Open eir site will be refused where a completed ID application form has not been submitted and approved by Open eir.*
 - i) *All accredited persons must display the Open eir contractor ID while working on Open eir premises.*
 - j) *Open eir uses closed circuit TV in certain of its secure facilities. While Open eir will endeavour, by way of signage, to notify persons on the facility of the use of CCTV, the cardholder acknowledges that CCTV is used by Open eir in certain secure environments. This information is used to investigate security incidents or failure to comply with security procedures only*
 - k) *The ID card must be surrendered to Open eir, if the cardholder has left the employment of the Operator. Open eir must be informed immediately of this event.*

Appendix S – Quotation Infrastructure Build

Quotation Infrastructure Build (QIB)/Provide Infrastructure Build (PIB) Process

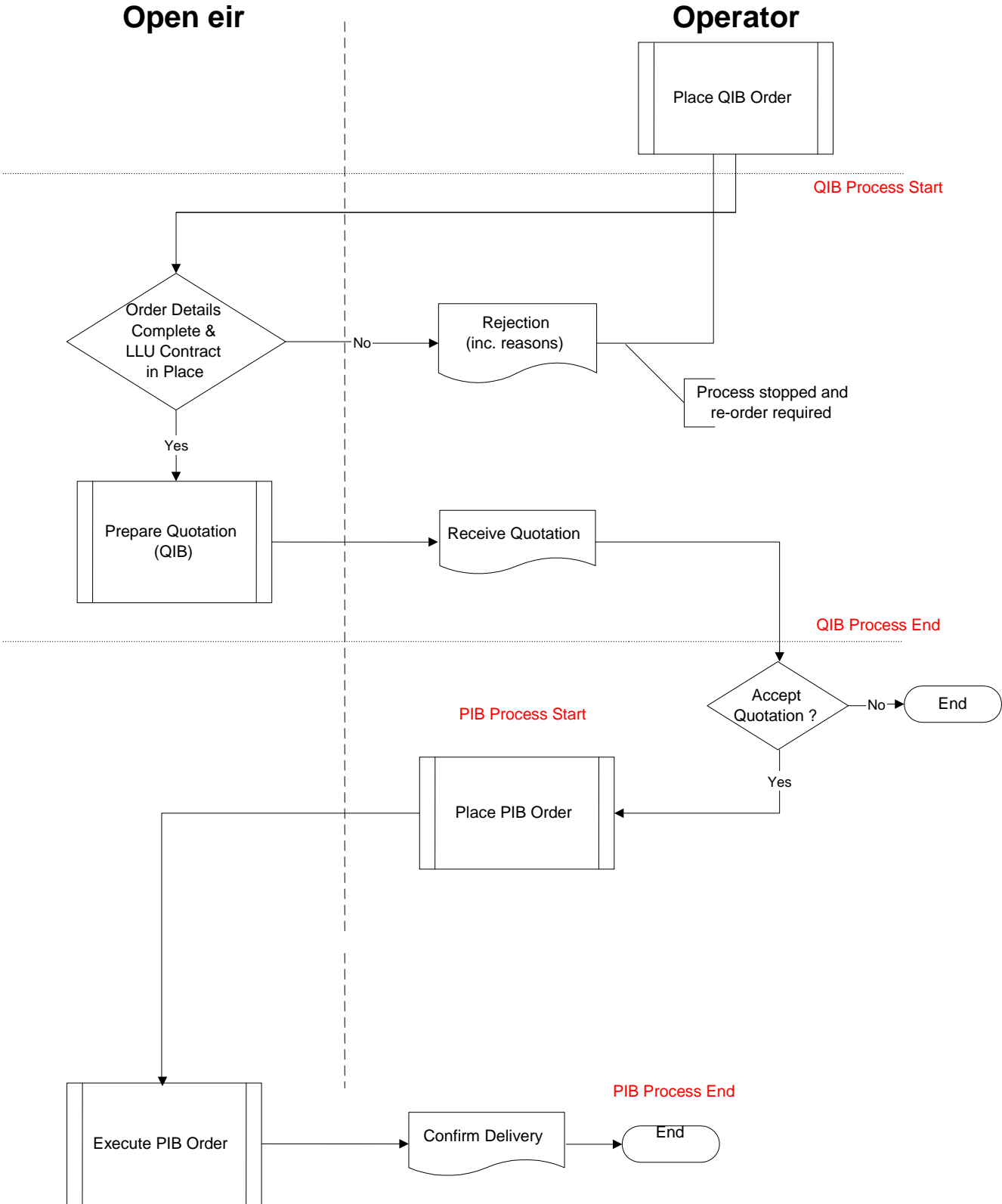



Appendix T – CoLo CEI Backhaul Connection

Request for CEI Backhaul Connection

Email Subject title must be “Physical CoLo for CEI – Backhaul connection - [OAO]”

Contact Details: Operator/contractor contact details (company, name, position, phone number, email).

Exchange information – name, short code identifier, address [enter data]

Operator Footprint Codes/Location ? [enter data]

Requested UUB box/chamber

- enter X-Y coordinates (plus Coordinate Ref System)

Related Duct Access product elements:

Confirm OAO has availed of Duct Access product? Y/N [enter date]

Confirm OAO has achieved ‘UUB box/access accreditation’ ? Y/N [enter date]

Confirm Duct Access “Equipment in UUB box/chamber” order has been submitted ? Y/N [enter ref no.]

Confirm Duct Access “Equipment in UUB box/chamber” order has been approved ? Y/N [enter date]



Appendix U – CoLo Rack Interconnect Tie Cable

Order Form for Rack Interconnect Tie Cable

Email Subject title must be “Physical CoLo – Rack Interconnect Tie cable - [OAO]”

Contact Details: Operator/contractor contact details (company, name, position, phone number, email).

Exchange information – name, short code identifier, address [enter data]

First Operator **Existing Footprint Codes**/Location ? [enter data]

Note: If applicable please include site drawings

First Operator **patch panel** in Footprint ? Y/N

- Connector type ? [enter type]

Second Operator **Existing Footprint Codes**/Location ? [enter data]

Note: If applicable please include site drawings

Second Operator **patch panel** in Footprint ? Y/N

- Connector type ? [enter type]

Version Control History

| Version | Status | Update | Effective Date |
|---------|--------|--|----------------|
| 1 | | First draft based on initial process review meeting on 15/3/2001 Document not seen by eircom and Operators | 30/3/2001 |
| 2 | | Highlights of fault repair, planned maintenance and billing processes added. | 09/04/01 |
| 3 | | Fault repair etc fleshed out. Other amendments proposed. eircom comments of 10.09.01 appended. | 10/04/01 |
| 4 | | Result of meeting 12th April with eircom and BT | 17/04/01 |
| 5 | | From Forum meeting: Forms in Appendix B added from original eircom colo proposal Forms in Appendix A,B,C and F proposed by COMREG Proposed Workflows added as Appendix K Text changes to 3.5.2, 3.7.3 (Bespoke Surveys), 4.2.1, 3.9.5, 3.15 All references to SLAs and timelines removed and new document ref. ODT/775/8/1 created for discussion by expert group and submission to forum. | 19/04/01 |
| 6 | | Arising from expert group meeting of 20th April: Forms added and revised as agreed Workflows added and revised as agreed Text changes as marked in this document Proposed for adoption by the expert group, subject to inclusion of missing information from eircom and BT | 23.04.01 |
| 7 | | Arising from expert group meeting of 25th April, final draft produced for agreement. No substantive issues outstanding. Issues for Forum which are outside of scope of Expert Group are identified. Issues which require further work but which are not showstoppers are explicitly identified. | 26.04.01 |
| 8 | | Arising from Forum meeting. | 1.05.01 |
| 9 | | Incorporating changes to 3.16 and Determination on “booking” for escorts. | 08.05.01 |
| 10 | | FSR form altered to include DC cable size | 16.05.01 |

| | | | |
|--------|-------|---|-------------|
| 11 | | Changes to Site Offer and Combined Full Survey and Site Offer diagrams in Appendix K. | 22.05.01 |
| 12 | | Update to IPM | 01.02.02 |
| 12b | | Update to IPM sections 7.1.3 and 8.3. Appendix O added. | 01.02.02 |
| 12.1 | | Update to IPM arising from forum meeting following particle experience Text changes made to 2, 3.7.5, 3.8.3, 3.9.5, 3.1, 5.2.1, 5.3, 5.3.2, Deleted 3.11.2 pre-installation site meeting. Inserted items 3.8.6, Changes to Appendix B, I | 10.07.02 |
| 12.1A | | Updated by eircom following Industry comments Text Changes 3.2, 3.7.3, 3.7.5, 3.8.3, 3.10.1, 3.11.2, 3.16, 5.2.1, 5.2.2, 5.3, 5.3.3, 5.6.4, 8.2 Changes to Appendix B, Reformat of Appendix I Inserted 3.18 & Appendix P | 04/09/02 |
| 12.1B | | Inclusion of section 3.19 “Expansion of Capacity” Request Updated contact 5.3.4 Text Added 3.14, Fig 3.1 EOC timelines | 24/12/02 |
| 12.1b1 | | Test Change replace ODTR with ComReg | 10/01/03 |
| 13.0 | | Deletion of duplicate Appendix N | 22/01/03 |
| 14.0 | | Addition of unescorted access Section 5 - 5.1.5, 5.3.3, 5.5.3, Appendix M, Appendix Q | 08/03/06 |
| 15.0 | | Industry IPM Review | 18/03/10 |
| 15.1 | | QIB/PIB Process 3.12, 8.2, Appendix S | 18/11/10 |
| 15.2 | | Correction to section 8.2, Billable events | 21/4/11 |
| 15.3 | | Changes to Unescorted Access Times, Escorted Access Probation Period; Full Survey, Site Offer & CFSSOR Timeline Improvements | 25/7/11 |
| 15.4 | | Addition of WSEA to QIB /PIB Process 3.12 | 10/11/2011 |
| 15.5 | | Update to section 3.12 QIB timeline | 16/02/2012 |
| | | Rebranding | 30/09/2015 |
| 15.6 | | Addition of CoLo for VUA | 01 /10/2016 |
| V16.0 | Final | This document is based on V15.6 Implementation of Standardised Change Control. | 16/06/2017 |
| V17.0 | Final | D10/18 changes. | 31/05/2019 |