

open eir¹

Duct Access

Product Description

¹ open eir is a trading name of eircom limited, Registered as a Branch in Ireland Number 907674, Incorporated in Jersey Number 116389, Branch Address : 1 Heuston South Quarter, St. John's Road, Dublin 8

Version Control

Version	Status	Update	Effective Date
V4.03	<u>Final</u>	<u>D10/18 WLA ingress / egress changes</u>	<u>21/02/2019</u>

This document follows change control procedure:

Proposed is defined as a document status when the approved document is uploaded to Proposals Section of open eir Website.

Final is defined as a document status when the approved document is uploaded to the relevant section of the open eir Website following the publication period.

For information:

- Historical Document History Table located at end of Document.
- **Publish means the action of uploading a document to the relevant section of the open eir website be it the Proposal section or appropriate product section..**
- If there are changes to the document between 'Proposed' and 'Final', change control operates.



Contents

1.	Preface.....	5
2.	open eir Duct Access Overview.....	5
3.	Product Features – Duct Access.....	9
3.1	Points of Ingress and Egress.....	9
3.2	Underground Utility Boxes / Chambers	10
3.3	Cable.....	10
4.	Duct Access Process Overview.....	10
4.1	Prerequisites.....	11
4.2	Pre-Order Survey / Design activities.....	11
4.3	Order	14
4.3.1	Provide Duct Access.....	14
4.3.1.1	Interconnection to Operator chambers.....	15
4.3.1.2	Operator installs own fibre cable	16
4.3.2	Exit Sub-Duct Order.....	16
4.4	Major Infrastructure Programme:.....	17
4.5	Supervised Access.....	17
4.6	Equipment	17
4.7	Fault Handling and Repair.....	18
4.7.1	Sub-Duct Major Fault	18
4.7.2	Sub-Duct Minor Fault	19
5.	Reservation Order	19
6.	Maintenance.....	20
6.1	Planned Maintenance.....	20



<u>6.2</u>	<u>Planned & Unplanned Maintenance by the Operator</u>	<u>20</u>
<u>7.</u>	<u>Supervised Access</u>	<u>20</u>
<u>7.1</u>	<u>Supervised Access Request</u>	<u>21</u>
<u>7.2</u>	<u>Supervised Access Request Process</u>	<u>21</u>
<u>7.3</u>	<u>Changes to Supervised Access Requests</u>	<u>21</u>
<u>7.4</u>	<u>Supervised Access Times</u>	<u>21</u>
<u>7.5</u>	<u>Supervised Access Records</u>	<u>22</u>
<u>8.</u>	<u>Billing</u>	<u>22</u>
<u>9.</u>	<u>Health and Safety Requirements</u>	<u>23</u>
<u>10.</u>	<u>Version Control History</u>	<u>25</u>

1. Preface

This document describes the open eir Duct Access product. Document 13/11 issued by ComReg contains Decision Instrument for the Wholesale Physical Network Infrastructure Access (WPNIA) market which states that open eir shall provide duct access where reasonably available.

2. open eir Duct Access Overview

The open eir Duct Access product offering provides Operators with the opportunity to have their fibre cable carried within a sub-duct installed in open eir's duct infrastructure between nominated open eir ingress and open eir egress locations in order to offer electronic communication services to Operators customers. It is the Operator's responsibility to provide connectivity from their network to the nominated open eir ingress and egress locations. Operators are required to forecast their requirements on a quarterly basis through their open eir Account Manager.

Duct access will be provided over trench routes through the open eir access network used to deliver the local access (WPNIA) element of open eir services. Operators should contact their open eir Account Manager for all queries regarding access.

The open eir duct network is designed as an exchange centric deployment - this means that the duct leaves an exchange in a tree and branch fashion. The sub-duct network built for NGA, which is housed in the open eir duct architecture, is designed to support network flexibility points at open eir cabinets. In NGA areas, sub-duct is installed in unbroken duct lengths that are as long as possible.

[Access to the open eir duct network is via Underground Utility Boxes \('UUB'\), commonly referred to as joint boxes or chambers.](#)

When an Operator submits the X-Y co-ordinates of their ingress and egress points open eir will determine and advise the most suitable open eir ingress/egress ~~point/chamber~~UUB which is nearest the Operator ingress/egress point, and if accepted open eir will then proceed to survey/design a solution that allows the Operator access the open eir duct in accordance with existing open eir ~~planning~~Civil Engineering Infrastructure (CEI) principles and rules (which will be sent to Operators after signing up to the product schedule).

Duct access may be offered at any technically/operationally suitable ingress/egress ~~point/chamber~~UUB (eg provided there is sufficient space in the UUB for safe working and to minimise the risk of disturbance to existing infrastructure in the box/chamber). ~~open eir recommends that the ingress/egress points outside the open eir exchange / cabinets / final Distribution Point~~

~~(DP) are the optimal locations from an engineering point of view to offer interconnection with an OAO chamber for the purpose of OAO duct access provision~~

~~All open eir sub-duct' is for the sole use of the OAO – there is no right to sub-licence sub-duct to a third party.~~

~~**-Available in-situ spare sub-duct:**~~

~~If a spare sub-duct is available then, subject to open eir CEI principles, it will be made available to the Operator. This could be indicated by a desktop survey, and could be confirmed by a field survey. There is no need for RRT/design/install subduct activities. Only 'connect existing sub-duct' activity is required.~~

~~It is possible to access existing multi-core sub-duct at the UUB locations where the sub-duct is jointed together - this can be determined via a field survey. An Operator can access the sub-duct at any such suitable UUB locations, or open eir could run extra sub-duct up to the agreed OAO nominated UUB location. Open eir will extend this sub-duct into the Operator's chamber through the interconnecting duct. It is not technically feasible to consider access to breach the sub-duct between an open eir exchange and a cabinet as the sub-duct is multicore sub-duct carrying other services—ingress/egress would require cutting into multicore sub-duct along a route which raises engineering risk and technical difficulties.~~

~~**'OAO controlled' sub-duct:**~~

~~Spare in-situ sub-duct should be consumed in the first instance for efficient space usage. However, an OAO can now additionally request that a new sub-duct(s) be installed – even if a spare sub-duct is already available in a multi-core sub-duct - this will be subject to approval by open eir . This would allow the OAO more control as to where they would break into the sub-duct.~~

~~For operational efficiency reasons this 'OAO controlled sub-duct' installation will be done by open eir, deploying the same sub-duct that is used by open eir, but labelled to indicate it is controlled by a specific OAO.~~

~~[Note that when 'UUB access' is permitted the OAO will have control over the 'OAO controlled sub-duct' - ie can access, cut and connect their sub-duct within the open eir UUB. However sub-duct maintenance (UUB-UUB, not duct joints) will be carried out by open eir.]~~

~~'OAO controlled sub-duct(s)' can be requested in other scenarios, as a variant to the standard sub-duct access product offering.~~

Different upfront / annual licence fee pricing will apply to this product variant.

~~The nominated open eir ingress and open eir egress locations will provide duct connectivity on any of the following point to point duct routes:~~

- ~~• chamber outside open eir exchange, or other suitable chamber, to chamber outside final DP outside customer premises~~
- ~~• chamber outside open eir exchange, or other suitable chamber, to chamber outside open eir cabinet~~
- ~~• chamber outside open eir cabinet to chamber outside final DP at customer premises~~

The following diagram provides an overview of the open eir Duct Access product:

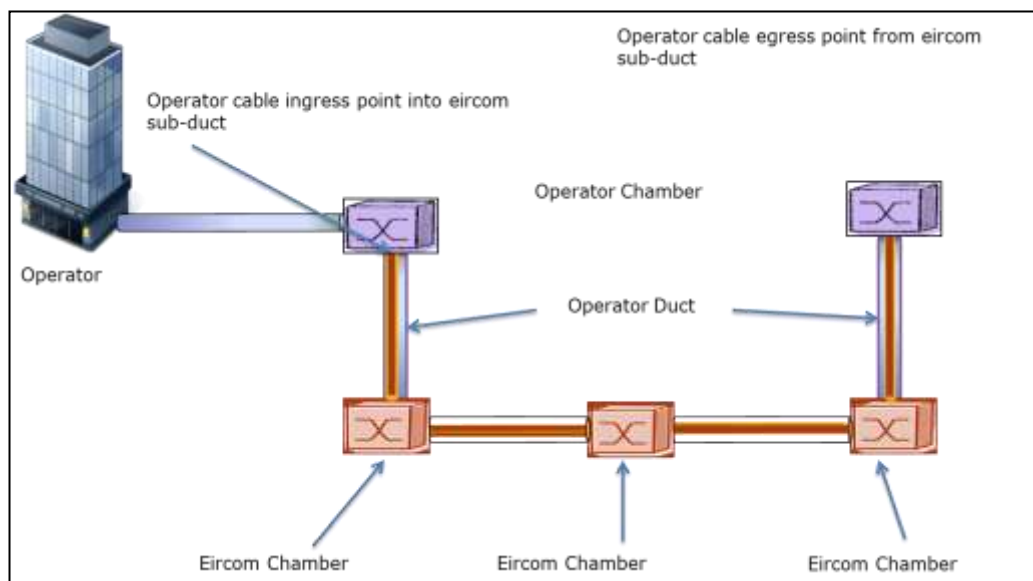

No available spare sub-duct:

Assuming space is available, open eir will install open eir sub-duct – single, 3-way or 7-way - from the nominated open eir ingress to open eir egress points. See the Duct Access Technical and Operational Manual for details. open eir will assign a single sub-duct to an Operator and will feed this sub-duct into the Operator’s chamber through the interconnecting duct.

Duct access is now available for the Operator to blow-in it's cable into the open eir sub-duct from the Operator's point of ingress to the Operator's point of egress.

The interconnecting duct between the Operator and open eir chambers will be installed by the Operator. The sub-duct between open eir ingress and egress chamber and the Operators chambers will be supplied by open eir and installed by the Operator. This point of ingress/egress to the open eir chamber is the demarcation point. All duct and sub-duct within and between the open eir ingress and egress chambers is maintained by open eir. All other equipment outside of the demarcation point is maintained by the Operator.

A splicing chamber outside open eir chamber may be required for the purposes of fibre splicing by the Operator – see section 2.4 Technical & Operational manual. Existing ISI chambers may be used if they are located close to any of the nominated open eir ingress or egress points and if open eir can get the sub-duct into the chamber.

The Operator may also require access to an open eir chamber for the purpose of fleeting (also known as mid-point blow). If fleeting is required, the Operator will request the services of a Clerk Of Works through their open eir Account Manager.

Fleeting: the Operator requires to install their fibre cable from a point in the network where fibre can be blown in 2 directions, giving Operators the longest possible run of fibre, without splicing. The Clerk of Works will be provided by open eir at the expense of the Operator. The Operator must agree in advance with open eir the location of any fleeting point.

Operators' staff or their sub-contractor staff must be accredited by open eir and work must be carried out to open eir's standards. Accreditation/site safety induction requirements are addressed in the 'eir Contractor / Other Operator Health & Safety Management Requirements' document,.

The Operator is responsible for installation of the final lead-in to their customer premises

open eir will maintain the open eir installed sub-duct within the open eir network i.e from the break-in point of the open eir ingress chamber to the break-out point of the open eir egress chamber.

The Operator is responsible for fault handling on their cable and replacement of any faulty cable. No repairs can be carried out in open eir sub-duct or any open eir chamber.

For the avoidance of doubt, this duct access product will not be available in cases where construction of new civil work is required. Duct availability will be managed by open eir in

| accordance with open eir's ~~network engineering rules~~ CEI Principles, regardless of which Operator requests it.

| Duct will ~~be~~ become available for other Operators if the Operator ceases or does not maintain payment of license fees.

Major Infrastructure Programme

Where an Operator wishes to plan a major infrastructure programme, open eir (or eir's infrastructure access team for NBP), will provide the duct information in CAD GIS format. The Operator will use the information to design its fibre network and submit its high level design to open eir (or eir's infrastructure access team for NBP) who will validate the design and send a quote covering access to this duct infrastructure to the Operator.

When an Operator wishes to implement a major infrastructure programme, open eir will set up a joint project team with the Operator, to manage the implementation.

open eir considers a major infrastructure programme to be one that contemplates roll-out in at least 10 exchange areas with the intention to pass at least 10,000 premises.

3. Product Features – Duct Access

The main features of the product are:

- Provides Operators with ability to offer electronic communication services to customers
- Permits Operators to provide fibre connectivity via a single open eir sub-duct between nominated open eir points of ingress and egress.

3.1 Points of Ingress and Egress

The point of ingress is where the Operators' cable physically enters the open eir sub-duct and the point of egress is where the Operators cable physically exits the open eir sub-duct along a defined route.

3.2 Underground Utility Boxes / Chambers

The Operators underground chambers will facilitate their splicing requirements and any associated equipment where required along the open eir defined route. For operational reasons open eir will not accommodate Operators jointing, splicing or any associated equipment in open eir's duct route, or open eir box/chambers.

open eir will provide sub-duct to the Operator. The Operator will provide a duct route between its chamber and the open eir ingress/egress box/chamber and core drill into open eir's box/chamber wall. The Operator will install the duct and sub-duct from its chamber into open eir's box/chamber. The core drill into the open eir box/chamber must be supervised by an open eir Clerk of Works.

Operators are responsible for making good and restoring the area surrounding the open eir box/chamber ("the surrounding area") to licencing authority standard. The Operators will blow their cable from the point of ingress in their chamber through open eir sub-duct to the point of egress.

The Operator is responsible for all jointing and associated work in its chamber. Note: Operators shall not place any equipment in open eir plant that may interfere or cause damage to open eir duct, sub-duct, box/chambers or equipment.

3.3 Cable

The Operators' fibre cable must conform to the International Telecommunications Union's recommendations to allow it to be carried within open eir sub-duct.

open eir will advise the Operator when the sub-duct route from open eir ingress to open eir egress chambers is complete (hand-over) to facilitate the Operator blowing in its cable from the designated point of ingress to the designated point of egress. open eir will not connect the cable on either the Operator's or open eir equipment at the ingress or egress points of the route or anywhere within open eir infrastructure.

open eir retains the right at any time to change the cable specification in accordance with open eir's workmanship standards per the Technical & Operational Manual (currently 6 month notice period) – this right does not apply to existing installations.

4. Duct Access Process Overview

An Operator can access information about the open eir duct network by using the 'Click Before You Dig' (CBYD) service – see the IPM for details.

4.1 Prerequisites

The Operator before submitting any request for open eir Duct Access must have signed the relevant Duct Access service schedule in the ARO.

4.2 Pre-Order Survey / Design

Should the Operator wish to avail of the Duct Access product they must first request a [number of survey/design activities carried out by open eir](#) before submitting an order. The survey/design [activities](#) will indicate if open eir has a suitable duct route available between the [requested UUBs](#); it [may propose alternative most suitable ingress and egress points](#); [it may include doing a Rod Rope & Test \(RRT\) to determine if a duct route is available](#); it may include designing a duct solution (eg [partial or full subduct required](#)) assuming space is available; and it will provide a price estimate to the Operator. The survey/design is not an order for Sub-Duct.

The survey/design process is divided into three stages, with Operator approval to proceed ~~to~~ from desktop [survey](#) to field survey [to RRT/Design](#) stage required. [Note that it is not a requirement to go through all of these stages.](#)

[Before an order can be placed an Operator must have achieved accreditation – see ‘eir Contractor / Other Operator Health & Safety Management Requirements’ document.](#)

4.2.1 Desktop duct survey

A desktop survey is a snap-shot at a point in time based on available information from open eir duct infrastructure records, and is not to be taken as an accurate indicator of actual duct availability at the time when the work is to be carried out. If the route requested is not valid it will be rejected. An up-front desktop survey charge applies

When an Operator requests a desktop survey:

(a) where a continuous sub-duct route appears to be available then the output is a drawing from the most suitable open eir ingress to egress points with measurements of route lengths and surface types to determine the annual licence fee. The relevant connection and annual licence fee charges will be provided.

(b) where the open eir inventory indicates gaps in the route sought it is unclear whether new sub-duct build is required to complete the route sought and unclear whether a new sub-duct design job is required to specify that build or unclear whether the nearest ingress/egress point/chamber is

suitable - then the output is to advise the Operator that a field duct survey is required along with the up-front charge.

open eir will provide a Survey/design Reference Number (SRN) to the Operator; this number will be used for all future correspondence / orders relating to that particular route.

open eir will respond to the Operator within 13 working days for a point-to-point desktop survey within the same open eir exchange or cabinet boundary. Multiple point-point requests will be treated as a project with timelines agreed with the Operator.

4.2.2 Field duct survey

If the Operator requests open eir to proceed with a field duct survey then an open eir technician will visit the access / intermediate nodes / egress sites to find physical evidence of the inventory sufficient to establish that the route exists, or that design and build is needed to complete the sub-duct route sought, or to determine the most suitable ingress/egress point/ chamber nearest the Operator ingress/egress point.

The output is either a drawing and the relevant connection and annual licence fee charges as at 4.2.1 (a) above where a continuous sub-duct route appears to be available, or the Operator will be advised that new design/build is needed.

~~As part of the new sub-duct design the new section will be subject to rod, rope and test (RRT). The up front charges for the RRT of the new section and the new sub-duct design charge, along with the annual licence fee for the full route will be provided.~~

open eir will respond to the Operator within 13 working days for a point-to-point field duct survey within the same open eir exchange or cabinet boundary. Multiple point-point requests will be treated as a project with timelines agreed with the Operator.

~~At this point the Operator will know the proposed suitable UUBs and can decide whether to proceed with the standard sub-duct product, or instead could request 'OAO controlled' sub-duct. This should be indicated on the order form in the IPM.~~

4.2.3 Rod Rope & Test / Sub-duct design

If the output of the field duct survey is that design and build are required and the Operator approves open eir to proceed to that stage then open eir will use the information gathered during

the survey/design stages to design a new route – and to evaluate the cost of the necessary build. This will include RRT of the new duct section – up-front charges apply. The output of this stage will be a drawing and the relevant installation and annual licence fee charges.

Where licencing authority consent is required to unblock duct during the RRT, the target timelines will be changed. The changes will be notified to the Operator when a new forecast date becomes available. If the consent is not granted then the survey/design request may be cancelled.

open air reserves the right to charge an excess fee if the cost of unblocking turns out to be more than 150% of the upfront installation fee. open air will seek to get agreement from the Operator before work continues on the RRT. If agreement cannot be reached with the Operator then the order may be cancelled.

open air will respond to the Operator within 30 days for a point-to-point new sub-duct design within the same open air exchange or cabinet boundary. Multiple point-point requests will be treated as a project with timelines agreed with the Operator.

The desktop survey and field survey can only be requested using the survey/design request form in Appendix A in the IPM – [this also applies to requests for RRT/design](#). The Operator will supply open air with a site location map² highlighting the x-y coordinates for the proposed chambers. The Operator will complete the survey/design request form and submit it to the open air Account Manager by e-mail.

open air will acknowledge receipt of the form within two working days, will check the form for completeness and either accept or reject the form by e-mail. Incomplete forms will be rejected and returned to the Operator for full completion.

All survey/design price estimates will be valid for 12 months, subject to published price changes; however duct infrastructure will not be reserved.

An on-site meeting may be required to resolve operational issues, such as determining the appropriate fleeing chamber.

[Operator fibre cable will always be installed in sub-duct. In exceptional cases, eg when the duct is full, open air will engage with the Operator to investigate alternative options including \(but not](#)

² *The map can be a Google page or ordinance survey map at street level highlighting the required ingress and egress points and should be in a soft copy attached to the e-mail.*

limited to) 'Direct Duct Access' subject to engineering rules. If granted the Operator will be responsible for installation of their fibre cable and will also be liable to open eir in the event of damage or latent damage (ie within 6 months) to open eir infrastructure/equipment. In addition, open eir will not be held liable for any future damage caused by open eir to the Operator's unprotected fibre cable.

If sub-duct cannot be reasonably provided then open eir will endeavour to provide dark fibre where reasonably available.

open eir will also send a Licence Agreement for duct access, to be signed by the Operator before an order can be placed (note where new sub-duct installation is required then final Licence Agreement signing is done when the duct route is handed over).

4.3 Order

The signed Duct Access License must be returned to open eir prior to an order being accepted (where new sub-duct installation is required the Duct Access Licence should be drafted, awaiting final details).

The processes for order handling and provisioning are set out in the order section of the Duct Access Industry Process Manual (IPM). The Operator completes the order request form and submits it to their open eir Account Manager by e-mail.

Up-front charges for connection / installation apply to this order. Ongoing annual licence fee charges apply following hand-over of duct route at the open eir ingress/egress points.

open eir will acknowledge receipt of the form within two working days, will check the form for completeness and either accept or reject the form by e-mail. Incomplete forms will be rejected and returned to the Operator for full completion.

4.3.1 Provide Duct Access

All orders for Duct Access will be placed using the order form in Appendix B in the IPM.

The open eir Product Manager will be the Point Of Contact for the duration of the provision process. The Operator will appoint a point of contact for operational reasons, to include name, contact number and e-mail address.

Point to point orders within same open eir exchange or cabinet boundary area will have a target provision timeline of 40 days from order acknowledgement, or 10 days where sub-duct is already fully in-situ. Multiple point to point orders, or point to multipoint orders within the same exchange or cabinet area, will be treated as a project with timelines agreed with the Operator on a case by case basis.

Where licencing authority consent is required to unblock duct, the target provision timelines will be changed. The changes will be notified to the Operator when a new forecast date becomes available. If the consent is not granted then the order may be cancelled.

open eir reserves the right to charge an excess fee if the cost of unblocking turns out to be more than 150% of the upfront installation fee. open eir will seek to get agreement from the Operator before work continues on the sub-duct installation. If agreement cannot be reached with the Operator then the order may be cancelled. If sub-duct cannot be reasonably provided then open eir will endeavour to provide dark fibre where reasonably available.

An on-site meeting may be required to resolve operational issues, such as determining the appropriate fleeting chamber.

When sub-duct has been made available at the open eir ingress and egress points and handed over to the Operator, charges will apply. The open eir Account Manager will advise the Operator when the sub-duct is available for use, ie. the date of hand over. The interconnect route to the Operators chamber may be completed at a later time.

4.3.1.1 Interconnection to Operator chambers

The interconnecting duct between the Operator and open eir chambers will be installed by the Operator. The sub-duct between open eir ingress and egress chamber and the Operator chambers will be supplied by open eir and installed by the Operator.

The Operator will be responsible for obtaining all necessary private and licencing authority consents (eg new interconnecting trench from Operator chamber to open eir chamber) and will be responsible for the execution of all preparatory civil engineering works required. Where applicable, Operators are responsible for using existing or building new underground chambers and for Operator jointing chambers where required. The cost of the length of sub-duct required from the open eir chamber to the Operator's chamber will be included in the price quotation provided by open eir. The Operator will install and is responsible for this sub-duct.

The Operator will advise open eir when they have completed their activities e.g. civil works, new chambers, and duct from open eir chambers to Operators chambers. open eir Clerk Of Works (COW) supervision is required in respect of all works at open eir infrastructure.

The Operators must submit documentation, maps, photographs, etc. to show that all the Operators' activities outlined above have been completed prior to arranging supervision for installing the interconnecting duct – see section 3.2 Underground Chambers.

When the Operator interconnection point becomes available, open eir will deliver to the Operator the section of sub-duct required from the open eir chamber to the Operator's chamber.

4.3.1.2 Operator installs own fibre cable

The Operator is required to inform their open eir Account Manager when they propose to install their cable through the sub-duct. This requirement is for Health and Safety reasons as other Operators staff or open eir technical staff may be operating along the requested route and rescheduling of the work may be required.

Operators are not required to have a Clerk of Works on site when they are installing their cable through the sub-duct.

Open eir Clerk of Works is only required when the Operator needs to fleet their cable at an open eir chamber or when the Operator requires access to open eir infrastructure

Any request for help from open eir during this process will be handled using existing process i.e. open eir Clerk of Works.

Emergency requests for Clerk of Works may be made at the time of installation of the Operators cable. Any such requests will be treated by open eir as urgent, however open eir cannot guarantee a Clerk of Works will be available. The Operator may have to reschedule their work to a time when open eir can supply a Clerk of Works.

The Operator will advise open eir when they have completed installation of their fibre cable in the open eir sub-duct.

Power requirements for Operators will be housed in separate mini-pillars or similar housing outside of open eir infrastructure and are the sole responsibility of the Operator.

4.3.2 Exit Sub-Duct Order

All orders for removing Operator cable from open eir sub-duct will be placed using the order form in Appendix C in the IPM. An up-front charge applies.

Should the Operator require access to open eir duct or chambers to remove their cable from open eir Sub-Duct they must contact their open eir Account Manager and request supervised escorted access.

Cease is finalised when Operator removes their cable from open eir sub-duct and all ducts and sub-ducts are sealed at open eir chambers.

4.4 Major Infrastructure Programme:

Operators will design its networks and combine such networks with the duct information supplied by open eir (or eir's infrastructure access team for NBP). Desktop surveys will be done by the Operator. The Operator's high level design will be returned in an agreed CAD GIS format. open eir (or eir's infrastructure access team for NBP) will validate the Operator's design and agree a time scale for the implementation of the infrastructure build with the Operator.

A signed Duct Access License for each open eir exchange area must be returned to open eir (or eir's infrastructure access team for NBP). Due to the scale of a major infrastructure programme, individual order forms are not required. A jointly agreed project plan will be used as the basis for workflow and billing.

open eir (or eir's infrastructure access team for NBP) will complete field duct surveys, to establish actual availability of duct space in the requested areas, to allow the Operator finalise its detailed plans. The final sub-duct design will be agreed jointly between the Operator and open eir (or eir's infrastructure access team for NBP) during the project management stage. The duct route will be provided as per the agreed arrangements within the project team.

4.5 Supervised Access

open eir will provide a representative to supervise all works carried out by the Operator in open eir duct, sub-duct or chambers. Supervised Access will be by prior appointment only. See section 6.

4.6 Equipment

Operators must not place or transit any other equipment in open eir sub-duct or chambers that may interfere or cause damage to open eir plant. Please refer to Technical & Operational Manual for maximum diameter of cable.

4.7 Fault Handling and Repair

- Open eir is responsible for maintenance of sub-duct in open eir infrastructure and network
- Operator is responsible for maintenance and repair of sub-duct outside of open eir network i.e from break-in and break-out points at the open eir ingress/egress chambers
- Operator is responsible for repair, maintenance and replacement of Operator fibre

If open eir sub-duct is damaged, open eir will request that the Operator remove their fibre cable from the sub-duct so that a repair is completed. Open eir will endeavour to make available a temporary new sub-duct if possible, so that the Operator can transfer their fibre cable out of the damaged sub-duct and into a spare sub-duct.

If the Operators fibre cable is faulty, the cable should be replaced as no repairs are possible within the sub-duct or in an open eir chamber.

Before contacting open eir, the Operator shall prove the fault out of their network and carry out their normal procedures to isolate the fault into their cable within open eir sub-duct.

In the event that open eir duct or sub-duct is damaged and open eir's **Service Assurance** team is on site, open eir will endeavour to facilitate the Operator with access to replace their cable, under supervised access, if required. Operators can remove and replace the damaged cable section by blowing in new cable through the sub-duct. For health and safety reasons the Operator must ensure that the optic fibre laser is powered off and removed from the faulty sub-duct before any repair of the sub-duct can take place.

Should both the Operator and open eir be unable to work safely i.e. restricted space etc., then open eir will allocate the Operator a time slot on site to replace their cable. Should the fault be in a section of open eir sub-duct which requires way-leave permission to access it, then open eir will apply to the licencing authority for such permission.

Supervised access will be by prior appointment and agreement from open eir.

4.7.1 Sub-Duct Major Fault

When the Operator localises a fault on the open eir sub-duct that is a public safety issue, the Operator must dial 1901 and report the fault to an open eir agent. The process is outlined in the Industry Process Manual (IPM). This service is available 365 days a year and is managed 24 hours a day. Please ensure the following information is provided to the open eir agent;

- Contact Name.
- Contact Telephone number.
- Geo Coordinates of location.
- The extent and nature of the works.

open eir will follow their dangerous plant process and dispatch a crew to make the area safe. open eir will repair the damage as soon as possible. If the damage is not repaired within 48 hours, open eir will inform the operator of progress.

4.7.2 Sub-Duct Minor Fault

Operator reports the fault to the open eir Account Manager. Please ensure the following information is supplied;

- Contact Name.
- Contact Telephone number.
- Geo Coordinates of location .
- The extent and nature of the works.
- A map of the location.

A local open eir representative will visit the site and evaluate the problem. The representative will ensure the sub-duct is repaired as soon as possible. If the damage is not repaired within 48 hours, open eir will inform the operator of progress.

See The Industry Process Manual for further details.

5. Reservation Order

When the survey is complete, an Operator may decide to reserve space in the proposed duct route ahead of placing an order for duct access.

Once a reservation order has been accepted it will be recorded by open eir. That reservation will then be taken into account when assessing any subsequent requests for space in such ducts.

However an Operator cannot reserve space in open eir ducts if for a publically funded competitive bid. Third parties such as licencing authorities or government departments may provide public funds which are usually allocated on the basis of a published competitive tender. In these situations it is important to ensure that space (especially where this is limited) is allocated to the winning bidder and not all Operators participating in the bidding process.

The reservation order process is outlined in the Industry Process Manual.

~~OAO must submit a cease reservation order to stop the charges.~~

6. Maintenance

6.1 Planned Maintenance

Planned Maintenance may result from open eir's own network requirements or as directed by a third party e.g. Licencing Authority road widening scheme.

If open eir intends to carry out any planned maintenance work which may affect the Operators cable, open eir will notify the Operator via their open eir Account Manager giving a minimum of 10 days' notice of any work commencing. open eir will email the Operators Point Of Contact (PoC) informing them of the proposed works. The open eir point of contact will liaise with the Operator regarding dates for the move and notify them of any work the Operator needs to undertake to facilitate the work.

Where route diversion/retirement is required by 3rd parties, open eir will inform all Operators and it will be up to the Operator to make arrangements/representation with respect to their plant in/on the affected duct route.

6.2 Planned & Unplanned Maintenance by the Operator

Should the Operator want to carry out planned or unplanned maintenance or inspection of their cable within open eir sub-duct they should inform their open eir Account Manager. Supervised access if required will be charged.

7. Supervised Access

Operators and their representatives must only enter open eir duct or chamber under supervised access for the purpose of core drilling into open eir's chamber or fleeing the Operator cable or visually inspecting their cable.

open eir will provide a representative to supervise all access to its duct, sub-duct and chambers. This representative will direct the Operator to the exact location and depth of the core drill and where their duct should enter open eir's chamber wall.

The open eir representative will supervise all Operator representatives while they are carrying out work in open eir duct, sub-duct or chambers. This will be by prior appointment and agreement from open eir.

7.1 Supervised Access Request

Where an Operator requires to access open eir duct, sub-duct or chambers they must request supervised access by prior appointment using the supervised access record form provided in the IPM. Forms will be sent by e-mail to the open eir point of contact.

open eir will use reasonable endeavours to provide a representative past the booked time, should the Operator request it. Operators will be charged for the booked time or the actual time, whichever is the longer. Where access is requested by more than one Operator to the same chamber at the same time access will be provided on first come first served basis should it prove unsafe to allow the two or more simultaneous access requests for work to proceed at any chamber.

7.2 Supervised Access Request Process

All access to open eir duct, sub-duct or chambers shall be by prior appointment. The Operator will email a completed Supervised Access Record form to the open eir point of contact which will be acknowledged by end of the working day following the day in which the form was dispatched. open eir will endeavour to provide an appointment following a minimum notice period of 3 Working Days from receipt of request.

7.3 Changes to Supervised Access Requests

Should it become necessary for an Operator to reschedule or cancel an Access Request, they should make contact with the open eir point of contact at the earliest opportunity. Should the change be made within four working hours of the scheduled visit then open eir will be entitled to charge for the visit.

7.4 Supervised Access Times

open eir will endeavour to meet Operator requirements for supervised access. Where open eir cannot meet these requirements open eir will work with the Operator to reschedule the appointment to a mutually agreed time and date.

In some locations time restrictions may be imposed on open eir by a third party e.g. Licencing Authority and access will only be allowed outside normal business hours.

Most access visits are expected to take place during normal office hours on week-days (Standard hours). In some locations time restrictions may be imposed on open eir by a third party e.g. licencing authority and access will only be allowed outside normal business hours. Where these licencing authority restrictions apply or the Operator request is outside Standard Hours open eir shall make every effort to provide staff on a roster to provide access but at a higher charge.

Standard Hours are 0900 to 1600 Monday to Friday, Excluding public holidays. All other times are considered outside standard hours.

7.5 Supervised Access Records

On completion of an access visit, the open eir representative will complete a Supervised Access Record form detailing:

- the site visited
- the time and duration of the access visit

The Supervised Access Request form will be used by open eir as the basis of the billing record for the access visit.

8. Billing

There are up-front survey/design charges (desktop survey, field survey, and 'new sub-duct design' which include rod/rope/test charges), up-front duct connection or duct installation charges, and ongoing annual licence fee charges associated with this product. A charge for ceasing a duct route will apply.

Survey/design (incl. RRT) charges are payable on survey/design request.

When the duct access licence is signed the order can be placed and the upfront connection / installation charges shall be billed. The annual licence fee will be billed from the date of hand-over to the Operator.

The Operator may cease a completed duct route with a proportionate rebate of licence fee within 6 months. open eir may terminate duct path if it is not used by the Operator within 6 months. An exception applies where the Operator has applied to the licencing authority for a way-leave - the Operator must furnish supporting documentation indicating that the way-leave has already been applied for in a timely manner (within 2 months) and is pending approval. The maximum duct licence fee proportionate rebate to be 6 months.

Charges for supervised access and accreditation will be billed where appropriate.

Billing shall be carried out on a six monthly basis in advance and the services shall be identified on the bill. A 3-month billing cycle is available for Operators who do not want 6-monthly billing.

Bill is issued on a per exchange basis, showing all duct routes from that exchange.

Major Infrastructure Programmes: billing may be done as part of the overall contract ; an upfront charge for provision of CAD format duct information applies ; a design validation charge will be charged upfront ; project management fees will also apply.

Each duct route is licenced per exchange ~~and/or per cabinet~~. The licence can be modified for additional ~~exchange cabinet~~ routes ~~and/or additional cabinet final DP routes~~ (and extensions ~~to final DP~~) using a Deed of Variation.

In the event that an Operator has a query regarding the bill they should contact their open eir Account Manager.

Duct Access charges
Provision of Infrastructure records (Major infrastructure programme only)
Survey/design: Desktop Duct Survey (n/a for major infrastructure programme)
Survey/design: Field Duct Survey
Survey/design: New sub-duct design
Survey/design: New sub-duct design - Rod, Rope, and Test per 100m (or part thereof)
Design: Validate Operator high level network sub-duct design (major infrastructure programme only)
Project Management (major infrastructure programme only)
Order after RRT to install for first 100m
Order after RRT to install per subsequent 100m (or part thereof)
Connect existing sub-duct route
Exit/cease sub-duct route
Duct Reservation

Table of up-front charges

9. Health and Safety Requirements

All health & safety and accreditation/site safety induction requirements are addressed in the eir Contractor / Other Operator Health & Safety Management Requirements document.



10. Version Control History

Version	Status	Update	Effective Date
1.0		Rebranding	06/10/2015
1.1		Add Reservation	29/02/2016
1.2		Major Infrastructure Programme	17/06/2016
1.3		Removal of restrictions	03/01/2017
V2.0	Final	This document is based on V1.3 Implementation of Standardised Change Control.	19/06/2017
<u>V3.0</u>	<u>Final</u>	<u>Health & Safety update.</u>	<u>17/03/2018</u>
<u>V4.0</u>	<u>Final</u>	<u>D10/18 WLA ingress / egress changes</u>	<u>21/02/2019</u>