



open eir¹

LLU Soft Migrations Product Description

¹ open eir is a trading name of eircom limited, Registered as a Branch in Ireland Number 907674, Incorporated in Jersey Number 116389, Branch Address : 1 Heuston South Quarter, St. John's Road, Dublin 8



Version Control

Version	Status	Update	Effective Date
1.0		Rebranded	October 2015
V2.0	Final	This document is based on V1.0 Implementation of Standardised Change Control.	30/06/2017

This document follows change control procedure:

Proposed is defined as a document status when the approved document is uploaded to Proposals Section of open air Website.

Final is defined as a document status when the approved document is uploaded to the relevant section of the open air Website following the publication period.

For information:

- Historical Document History Table located at end of Document.
- Publish means the action of uploading a document to the website regardless of status or location.
- If there are changes to the document between 'Proposed' and 'Final', change control operates.



Table of Contents

1	Introduction	6
2	Product Scope	6
3	Product Description	6
4	Product Components	6
4.1	Soft Migration Product Components	6
4.1.1	Migration Components	6
4.2	ULMP Product Components	7
4.2.1	MDF	7
4.2.2	Metallic Path	7
4.2.3	Customer Premises	7
4.3	GNP Product Components	8
4.3.1	Number Porting	8
5	Product Technical Parameters	8
6	Spectrum Management	8
7	Product Availability	8
8	Continuity of Service	8
9	Services Responsibilities	8
10	Service Management	9
11	Order Handling	9
12	Maintenance	9
13	Billing Interfaces	9



14	Pricing	9
15	Terms and Conditions	9
	Annex A: Network Diagram.....	10
	Annex B: Parameters of the Metallic Path.....	10
	Annex C: Competing Services	15
	Annex D: Glossary.....	15
	Version Control History.....	16



Table of Figures

Figure 1: Soft Migrations - Unbundled Local Metallic Path - Network Diagram.....	10
Figure 2: Limits for the overall loss of the circuit relative to that at 800Hz.....	14

List of Tables

No table of figures entries found.



1 Introduction

This document defines the Product Description to provide a soft migration from SB-WLR and Line Share to a fully unbundled path including the porting of the number, if required. The processes supporting the implementation of the services will be outlined in the LLU Industry Process Manual. This document should be read in conjunction with the associated documents detailing processes and technical specifications of the service.

2 Product Scope

The Soft Migration product enables the operator to place an intra-operator product migration order, i.e. product changes with the same operator.

Existing SB-WLR PSTN and Line Share lines migrating to ULMP or GLUMP, with the same operator, are in scope for this service. Only single line orders may be placed for soft migrations.

DSP (Department of Social Protection) and NDD (National Directory Database) services will not be supported under ULMP or GLUMP. The Gaining Operator will have to reapply for these services on completion of the soft migration order.

3 Product Description

The Soft Migration product enables an end customer to move from SB-WLR and LS with one operator to full unbundling, with the same operator, without the need to send a technician to the exchange to carry out any jumpering tasks. Ordering and provisioning the service involves electronic transfer of an SBWLR account with Line Share to a ULMP or GLUMP account. In the case of GLUMP it also includes the porting of a PSTN number from the AP (Access provider) to the Operator.

See Network Diagram in Annex A.

4 Product Components

The Soft Migrations product consists of three components – the migration order, ULMP and GNP as detailed below.

4.1 Soft Migration Product Components

4.1.1 Migration Components

The soft migration will be catered for via two new Order types on the UG for the ULMP and GLUMP versions. The orders will be restricted to an Operator providing both the SB-WLR & LS service.

The soft migration order will consist of an electronic transaction and not require an open eir technician to visit the exchange or customer site. As part of the transaction the dial tone will be removed from the line but the Line Interface (LI) will be left in place. If the end-customer connects a phone to the open eir NTU they will be unable to make any calls including calls to emergency services.



As the LI is remaining in place the line will continue to carry DC voltage. Voltage will remain on the line therefore in order to avoid damaging exchange equipment the LLU Operator should not connect PSTN services to the line.

open eir reserve the right to remove the jumper at a later date for operational reasons such as freeing up LI's.

The LLU Operator will include the current Line Share block and pin details on the order. The porting of the end customer's telephone number will follow the current GLUMP process.

Bulk Migrations will be ordered via the UG. However, only single line orders per account will be accepted. Therefore, for an account with several LS lines the migrations will have to be carried out separately.

Once completed open eir will categorise the Line as a ULMP service. Ceasing the line will be via the Cease ULMP (CU) order. All faults will be logged as ULMP faults via the Fault ULMP (FU) order.

4.2 ULMP Product Components

4.2.1 MDF

The Operator will have access to the Unbundled Local Metallic Path facilities at their dedicated block on the exchange side of the MDF. This MDF block will be provided by the Operator according to open eir specifications, and will be installed on the MDF by open eir. The Operator will identify on this block, the exchange side, the line side and the pair numbers. The provision of a jumper between the line side of the MDF and the Operator's block on the exchange side of the MDF will be provided by open eir. The provision of a tie cable between the Operator's block on the exchange side of the MDF and their physical co-location space is detailed in the Technical Manual for Physical Co-location.

4.2.2 Metallic Path

The local metallic path is an in-situ two wire physical copper pair that provides a connection from the Main Distribution Frame (MDF) to the Network Terminating Unit (NTU) in the customers' premises, or to the Network Terminating Point (NTP), where no NTU is present on the customers' premises.

4.2.3 Customer Premises

The customers' side of the Network Termination Unit (NTU) or Network Termination Point (NTP) is the final point of open eir responsibility for the unbundled Local Metallic Path.

At the customers' premises the Operator will access the Unbundled Local Metallic Path via open eir's standard Network Termination Unit (NTU) (or Network Terminating Point (NTP) where no NTU is present). Where NTU equipment may need to be installed where no identifiable demarcation exists,



open eir would provide the Operator with a standardised Network Terminating Unit (NTU) by agreement to be installed and tested by the Operator subject to agreed installation standards.

Provision, installation, replacement and maintenance of any additional equipment/connections on the customer's side of the NTU/NTP required to provide Operator services to the end user(s) will be the responsibility of the Operator.

4.3 GNP Product Components

4.3.1 Number Porting

The GNP element of the soft migrations GLUMP product involves the porting of the telephone number from the DO's network to the RO's network. The porting is implemented on both the Switch and the IN (Intelligent Network).

5 Product Technical Parameters

The parameters of the Metallic Path are detailed in Annex B.

6 Spectrum Management

The provision of the Soft Migrations Product to an Operator will be dependent upon adherence to a Copper Loop Frequency Management Plan agreed under the National Regulator Definitions Industry Sub-group.

7 Product Availability

The Soft Migrations product is available to all Operators with both existing SB-WLR PSTN metallic paths and existing Line Share lines available for full unbundling.

Please see list of competing services in Annex C.

8 Continuity of Service

The customer may experience a partial break in service during the porting window. Unlike standard hard migrations the customer will not experience a short break in service due to jumpering.

9 Services Responsibilities

Prior to Order Completion

Any faults up to this point should be reported as per standard PSTN and Line Share repair process. Post Order Completion

The Operator must have the capability to localise any faults and pass to the Access Provider for repair using the standard ULMP repair process.

- The Access Provider will have responsibility for the provision, repair and maintenance of the Unbundled Local Metallic Path.



-
- The Operators are responsible any equipment an Operator attaches to the ULMP service (outside the service termination points).

10 Service Management

- Service management parameters, targets, procedures and processes for LLU are detailed in the LLU Industry Process Manual

11 Order Handling

- The interface between the Operator and open eir for the submission of orders will be as outlined in the LLU Industry Process Manual
- Processes for service provisioning will be as outlined in the LLU Industry Process Manual

12 Maintenance

- Processes for maintenance and repair will be as outlined in the LLU Industry Process Manual

13 Billing Interfaces

- Processes for billing will be as outlined in the LLU Industry Process Manual

14 Pricing

Prices are published on the open eir website, and a full list of prices may be found on the www.open.eir.ie website.

15 Terms and Conditions

Terms and conditions are contained in the Agreement for the Provision of a ULMP Service.

Annex A: Network Diagram

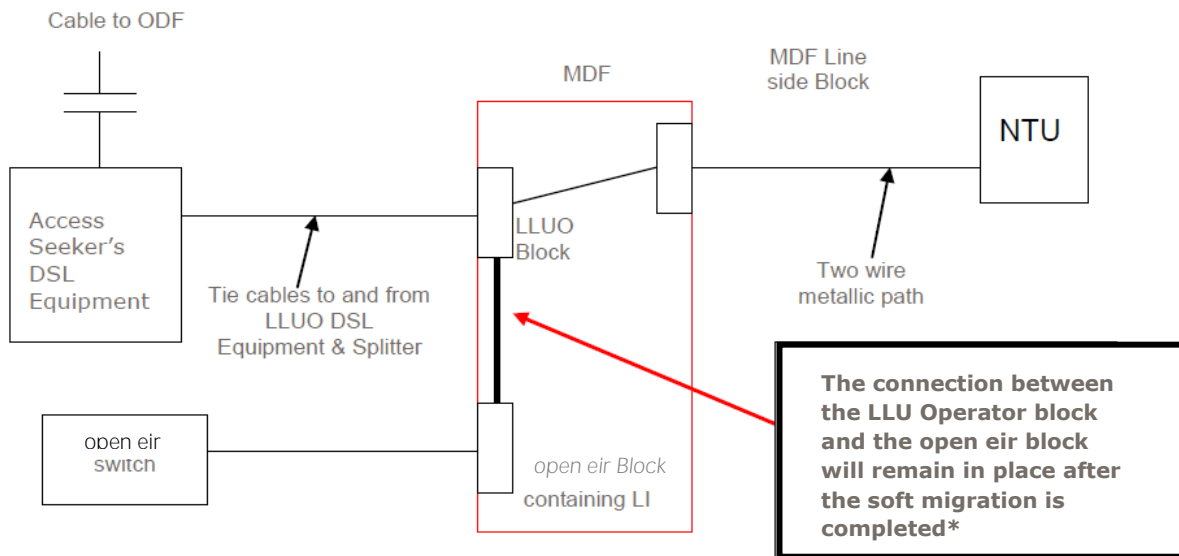

*open eir reserve the right to remove the jumper at a later date for operational reasons

such as freeing up LI's

Figure 1: Soft Migrations - Unbundled Local Metallic Path - Network Diagram

Annex B: Parameters of the Metallic Path

The standards have been in place since 1995 and are updated as and when needed. The relevant Operator will be advised of any changes to the parameters as required.

1. Summary of Transmission and Signalling Standards

1.1. The standard circuit for connection of a customer's terminal to the network is an unloaded cable pair. However loop treatment devices are used in special cases where there is a shortage of copper pairs.

2. Transmission Limit:

2.1. The maximum recommended attenuation for the customer's line is 10 dB at a frequency of 1020Hz.



3. Signalling Limit:

- 3.1. The recommended loop resistance for the customer's line is 1200 Ohms.
- 3.2. The cable gauge chosen should be the smallest which meets the above limits. Cables of lower gauge should be used close to the exchange and the gauge increased with distance from the exchange. A cable should only be jointed to the next largest (or smallest) cable gauge.

4. Local Network Standards

- 4.1. A standard, dedicated copper pair (2 wire) should be used if possible. However, the following line treatment devices may be used:
 - 4.1.1. Signalling loop extenders
 - 4.1.2. Line amplifiers
 - 4.1.3. Subscriber carrier systems.

5. Signalling and Feeding Limits

- 5.1. These limits are determined by the DC current required by the telephone receiver and the customer's home section in the exchange.
- 5.2. The telephone instrument needs a current of 20mA. Parent exchange signalling normally needs 16 mA. Hence the instrument is the limiting factor.

The resistance limit is:

$$R = \frac{(V_s.)}{I_{min}} - (R_f + R_i)$$

where

- R = permitted loop resistance
- Vs. = exchange feed voltage
- Imin = minimum feed current
- Rf = total feed resistance
- Ri = instrument resistance

Modern electronic instruments have a higher resistance (up to 400 Ohms) than older types.



$$R = \frac{(48) - (800+400)}{0.02}$$

$$R = 1200 \text{ Ohms}$$

A maximum value of 1200 ohms is allowed.

Note: Rf. for digital exchanges is 800 Ohms.

6. Physical Parameters

6.1. Line Insulation

6.1.1. At installation

6.1.1.1. The line, including the internal wiring and master socket with no telephone

connected to it, shall have minimum leakage resistances measured at 100V DC, as follows:

6.1.1.1. 10MOhms A leg to earth and B leg to earth

6.1.1.2. 10MOhms between line terminals (A & B).

6.1.1.3. The line, including the internal wiring, but excluding the master socket and with

no telephone connected to it, shall have minimum leakage resistances as follows:

6.1.1.4. 50MOhms A leg to earth and B leg to earth,

6.1.1.5. 50MOhms between line terminals (A & B).



6.1.1.6. Air spaced cables, tested with an Ohmmeter on the 500V range, shall have a minimum-leakage resistance of 500MOhms between cable pairs and moisture barrier.

6.1.2. For operation and maintenance

6.1.2.1. The line, including the internal wiring and the master socket with the telephone connected to it, shall have minimum leakage resistances as follows:

6.1.2.2. 1MOhms A leg to earth and B leg to earth.

6.1.2.3. 1MOhms between the A leg and the exchange battery and between the B leg and the exchange battery. (Alternatively, the voltage across a 20kOhm resistor connected between the A or B leg and the battery shall not exceed 0.5V).

6.1.2.4. 500kOhms A leg to B leg.

6.1.3. Maximum Loop Resistance

6.1.3.1. The maximum loop resistance shall be 1,200Ohms.

6.1.4. Jacks Modular Resistance

6.1.4.1. The resistor in the master socket should be 470kOhms.

6.1.5. Attenuation Distortion

6.1.5.1. The attenuation distortion of a connection, relative to 800Hz, shall conform to ITU-T Recommendation M1040.

Distortion shall be within the limits shown in Figure 1

The maximum recommended attenuation for the customer's line is 10 dB at a frequency of 1020Hz.

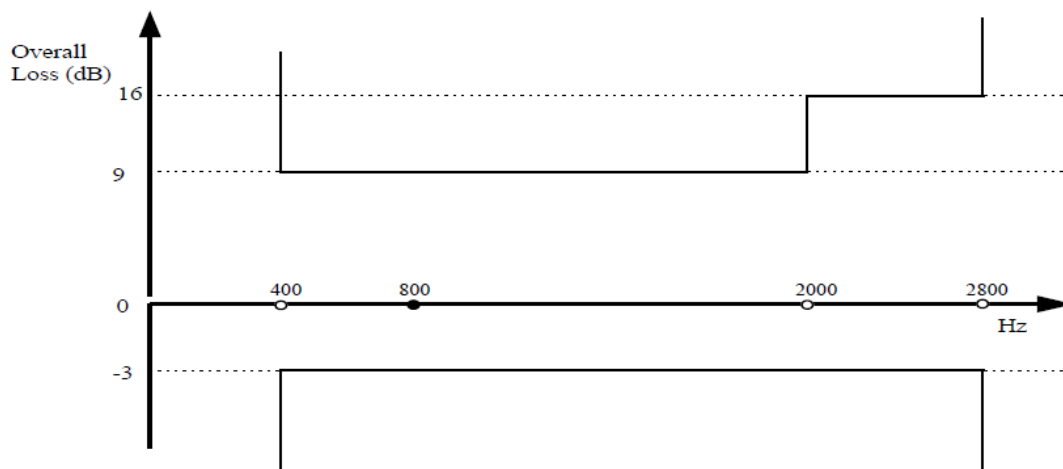

Figure 2: Limits for the overall loss of the circuit relative to that at 800Hz

Figure 2: Limits for the overall loss of the circuit relative to that at 800Hz.

6.1.6. Data Speed

6.1.6.1. No data rate is guaranteed on a telephony connection.

6.1.7. Random Noise

6.1.7.1. Random noise shall not exceed 50dBmOp.

6.1.8. Impulse Noise

6.1.8.1. Immunity from impulse noise is not guaranteed. While it should not significantly impair speech transmission, it may affect data transmission.

6.1.9. Maximum Transmission Level

6.1.9.1. The subscriber's equipment shall not transmit at levels exceeding -5dbm for PSTN.

Annex C: Competing Services

- Bit stream
- Line Sharing with another Operator
- Carrier Pre-Select (CPS) with another Operator
- Fixed Wireless Access
- Wi-Fi

Annex D: Glossary

GNP	=	Geographic Number Portability
ULMP	=	Unbundled Local Metallic Path
CPS	=	Carrier Pre-Select
SB-WLR	=	Single Billing through Wholesale Line Rental
OPERATOR	=	Authorised Operator – note: includes eir
GO	=	Gaining Operator
DO	=	Donor Operator
AP	=	Access Provider
IN Platform	=	Intelligent Network Platform
DSP	=	Department of Social Protection
NDD	=	National Directory Database
LS	=	Line Share



Version Control History

Version	Status	Update	Effective Date
1.0		Initial Draft	20 April 2012
1.0		Rebranded	October 2015
V2.0	Final	This document is based on V1.0 Implementation of Standardised Change Control.	30/06/2017